

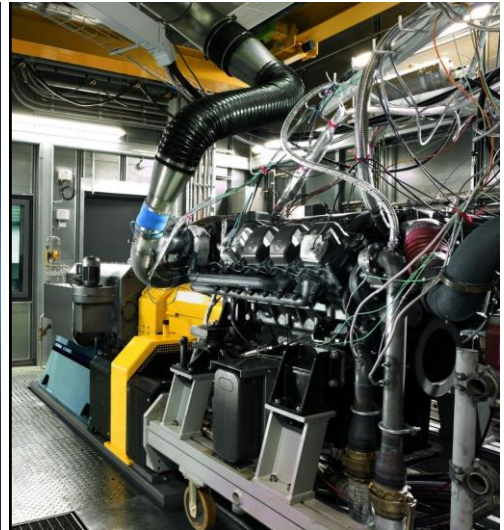

**Flowmeter for precise measurement of gas mass flow with long-term stability and high level of accuracy, under extreme conditions, also for applications in condensate and particle laden gases**



#### Measured variables

- gas mass flow
- standard flow rate
- actual flow rate
- pressure
- temperature

#### Examples of application

- engine test stations
- filter testing devices
- valve test benches
- turbocharger test stands
- climatic test chambers

#### Media

- single-phase gases or gas mixtures with air, nitrogen, oxygen, methane, natural gas, carbon monoxide, carbon dioxide, argon as dominant components

#### Design

- measuring tube with integrated transducer and flow straightener

#### Functional principle

- measurement of vortex shedding frequency  $f$  combined with absolute pressure and temperature measurement
- ultrasonic detection of the vortex



Kármán vortex street

#### Advantages

- long-term stability even under extreme conditions
- high turndown ratio (1:100)
- no moving parts
- corrosion resistant
- fast response time
- marginal pressure drop
- easy to use
- no separate evaluation unit necessary
- easy to install
- conform to e-CFR Part 1065

#### Particles, condensate, humidity in the gas

- Loading with particles such as dust and fibres does not affect the measurement, as long as these are no abrasions on the sensor
- relative gas humidity of less than 100 % does not affect the measurement uncertainty



### Types

Type	Article No.
ExactFlow II DN50 ZG1	B015/601
ExactFlow II DN80 ZG1	B015/602
ExactFlow II DN100 ZG1	B015/603
ExactFlow II DN150 ZG1	B015/604
ExactFlow II DN200 ZG1	B015/605

### Design / Functional principle

Measuring tube / vortex flowmeter with integrated transducer and flow straightener combined with precision absolute pressure transmitter 0.6 ... 1.2 bar abs; 0.1 % FSO and 4-wire Pt100 temperature sensor, class AA DIN EN 60751 as in Diagram 1 (ZG1), Page 4

### Measured variables

Measured variables	Unit of display
Gas mass flow m/t	kg/h
Standard flow rate NV/t	Nm <sup>3</sup> /h
Actual flow rate V/t	m <sup>3</sup> /h
Working pressure p	hPa
Working temperature T	°C

### Measuring ranges

Nominal diameter	Inside diameter [mm]	Mass flow* [kg/h]	Standard flow rate [m <sup>3</sup> /h]
DN 50	58.3	5 ... 345	4 ... 288
DN 80	80.0	9 ... 870	7 ... 724
DN 100	110.3	17 ... 1640	14 ... 1370
DN 150	150.0	31 ... 3050	26 ... 2540
DN 200	200.0	55 ... 5420	45 ... 4520

\* Mass flow for example for =  $t_B + 21$  °C and  $p_B = 1013$  hPa equates to a standard density of 1.204 kg/m<sup>3</sup>

Measurement accuracy	< 0.7 % of actual value (measuring range 2-100 % at +20 °C/1000 hPa)
Repeatability	± 0.15 % of actual value
Input/output section (see Accessories)	to achieve as great a measurement accuracy as possible, an input section of 20 x Di is recommended. The output section should be no shorter than 5 x Di. These can be reduced and operation without flow straightener is also possible. However, this leads in both cases to increased measurement uncertainties, which are dependent on the path of the pipeline, disturbances and the actual working flow velocity. With defined air intake requirements, such as suction filters, the input sections can be shortened to 10 x Di. (Please state when placing order).



#### Materials in contact with the medium

stainless steel 1.4571, 1.4404, 1.4301, ceramics, VITON®, aluminium

#### Working pressure

up to 1.2 bar / 120 kPa overpressure,  
higher working pressure in conjunction with integral flange connection and other pipelines on request

#### Working temperature ranges

Medium	-20 ... +80 °C (up to +240 °C on request)
Permissible ambient	-20 ... +50 °C

#### Transducer UVATP in the AS102 housing

Input vortex frequency	resolution : 0.125 Hz	
Input t: Pt100	resolution : 0.1 K	
Input p: 4-20 mA	resolution : 1 hPa time constant : 0.125 s	
2 analog outputs	4 ... 20 mA, resistance max. 500 Ohm 16-bit resolution (1/65000)	
Analog output A1 'high precision'	gas mass flow proportional time constant 4 s, frequency hopping >25% 2 s updating time 0.125 s measurement accuracy 0.7 % of actual value (in the measuring range 2-100 %)	
Analog output A2 'short time constant'	gas mass flow proportional time constant 0.065 s updating time 0.065 s measurement accuracy 1 % of actual value (in the measuring range 2-100 %)	
	The output signals are electrically isolated from the power supply. Optionally, the analog outputs can be electrically isolated mutually and from the inputs using an additional isolating amplifier.	
Supply	24 V DC	
Consumption	< 5 W	
LCD display in housing cover	1 <sup>st</sup> row: 'flow rate' or 'mass flow' 2 <sup>nd</sup> row: 'temperature and pressure' or 'error code'  2 x 16 digit, character height 5.5 mm working temperature range -20 ... +50 °C	<b>Article No.</b> A010/017

#### Electromagnetic compatibility (EMC)

according to EN 61 000-6-2 / IEC77



### Transducer and connection housing

Dimensions	150 / 100 / 80 mm (L / W / H)
Connection	PUSH IN PCB terminals; no tools necessary; apply pressure with a pen or screwdriver to separate strands; for wires with cross sections 0.14 ... 1.5 mm <sup>2</sup> ; feed through for shielded cables with outside diameter 5 ... 10 mm; shielded contact via metal cable glands

### Dimensions / Drawing 1 (ZG1)

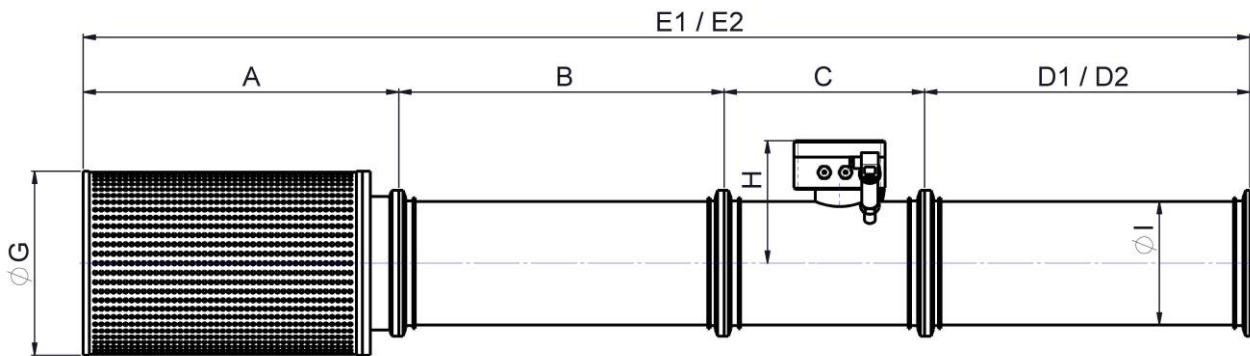

Nominal pipe size	Inside pipe diameter Ø I [mm]	Air filter A [mm]	Input section B [mm]	Sensor length C [mm]	Output section D1* [mm]	Output section D2** [mm]
DN 50	58.3	356	506	184	256	254
DN 80	80.0	401	806	189	406	404
DN 100	110.3	526	1006	254	506	504
DN 150	150.0	513	1518	280	768	759
DN 200	200.0	513	2018	330	1018	1009

Nominal pipe size	Overall length E1* [mm]	Overall length E2** [mm]	Air filter Ø Ø G [mm]	Height H [mm]		
DN 50	1302	1300	150	184.5		
DN 80	1802	1800	198	184.5		
DN 100	2292	2290	243	219.5		
DN 150	3079	3070	303	219.5		
DN 200	3879	3870	303	244.5		

\* with flange at the end of the output section (D1 and E1)

\*\* with flat pipe ends on the output section (D2 und E2)



### Accessories

	Description	Article No.
Raw signal output	via BNC connector 5 V (TTL); provides a frequency signal (vortex shedding frequency) in real-time	HWVAROH
PC software UCOM VTP	for configuring transducers UVATP via RS232 interface, PC connector cable RJ22 / D-Sub 9-pin (extra)	A010/053
PC cable RJ22 / D-Sub 9-pin	for configuring transducers; transducer connection: RJ22, PC connection: D-Sub 9-pin	A010/051
USB / RS232 Interface converter	connects PC with USB interface and Höntzsch programming adapter with RS232 interface, PC connection: USB plug type A programming adapter: D-sub 9-pin	A010/100
Calibration certificate m/t / f	minimum 6 standard values	KLB
DAkkS calibration m/t / f		on request

### Pipe sections for input/output sections for tension ring/chain assembly

Stainless steel 1.4301 or 1.4571

	Installation length [mm]	Article No.
Input section ZF/KF DN 50	506	B015/611-S01
Output section KF/ZF DN 50	256	B015/611-S02
Output section KF/flat DN 50	254	B015/611-S04
Input section ZF/KF DN 80	806	B015/612-S01
Output section KF/ZF DN 80	406	B015/612-S02
Output section KF/flat DN 80	404	B015/612-S04
Input section ZF/KF DN 100	1006	B015/613-S01
Output section KF/ZF DN 100	506	B015/613-S02
Output section KF/flat DN 100	504	B015/613-S04
Input section ZF/KF DN 150	1518	B015/614-S01
Output section KF/ZF DN 150	768	B015/614-S02
Output section KF/flat DN 150	759	B015/614-S04
Input section ZF/KF DN 200	2018	B015/615-S01
Output section KF/ZF DN 200	1018	B015/615-S02
Output section KF/flat DN 200	1009	B015/615-S04

### Pipe connection

with tension ring or chain

Flange on both sides for quick connectors.  
DIN or ANSI integral flange connection, on request.



**Installation position**

any	to ensure that the sensor remains operative in horizontal pipeline ducts, even with moderate condensate, it should be so installed that the connection housing points sideways
-----	--

**Air filter with cone flange (KF) connection for tension ring / chain assembly**

		Article No.
Air filter	DN 50	B015/611-S05
Air filter	DN 80	B015/612-S05
Air filter	DN 100	B015/613-S05
Air filter	DN 150	B015/614-S05
Air filter	DN 200	B015/615-S05

**Tension rings/chains for cone and intermediate flange (ZF) connection**

each with silicone flat seal ring

		Article No.
Ring	DN 50	B015/611-S03
Ring	DN 80	B015/612-S03
Ring	DN 100	B015/613-S03
Chain	DN 150	B015/614-S03
Chain	DN 200	B015/615-S03

**Pressure drop**

via the measuring tube under atmospheric conditions

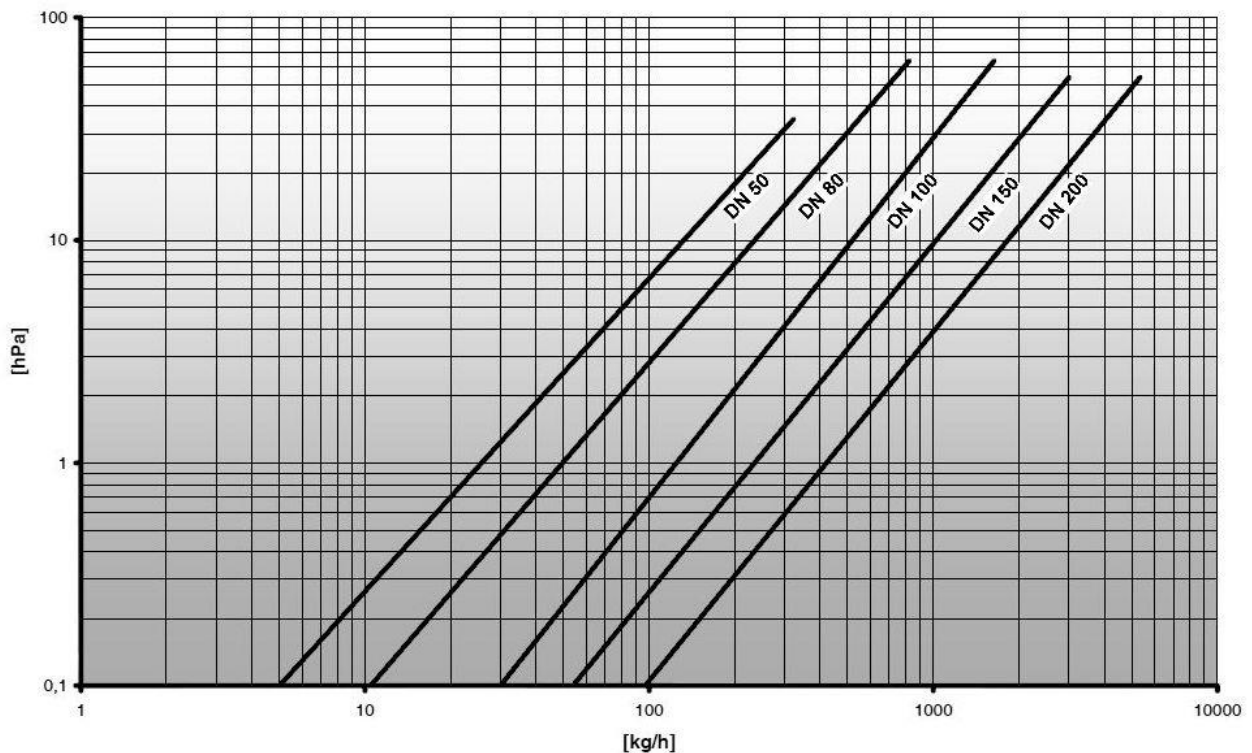



**Transducer connection diagram**

with added raw signal output via BNC connector 5 V (TTL) optional

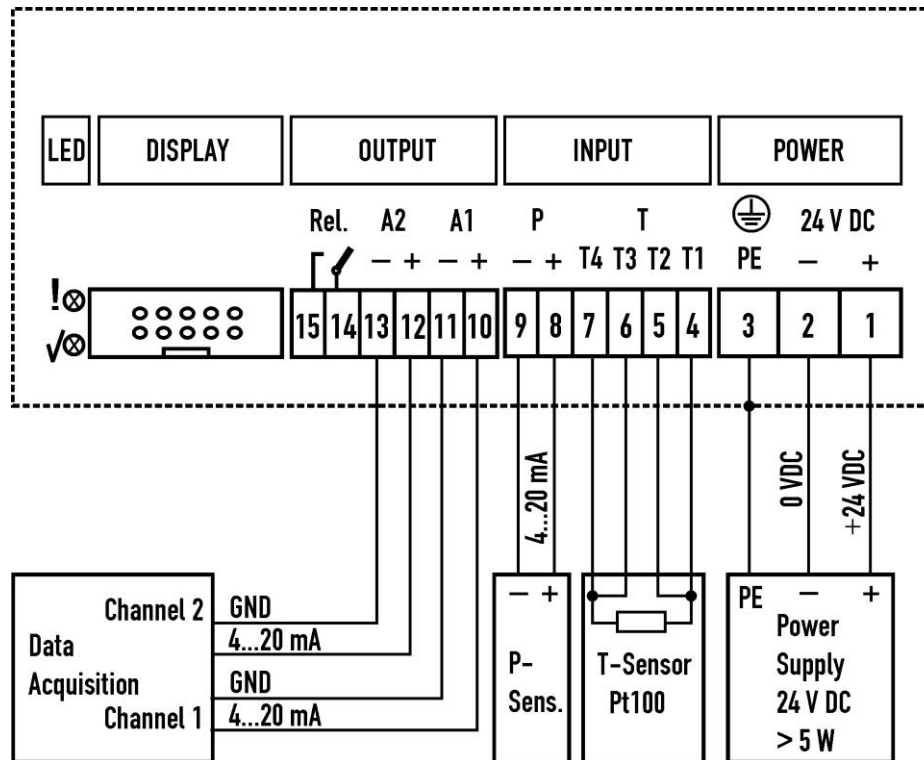

Viton® Dupont™

**Höntzsch GmbH**

Gottlieb-Daimler-Str. 37  
D-71334 Waiblingen (Hegnach)  
Telefon +49 7151 / 17 16-0  
Telefax +49 7151 / 5 84 02  
E-Mail info@hoentzsch.com

**จัดจำหน่ายโดย**

บริษัท โอเมก้า เมชเชอริง อินสตรูमेंท์ จำกัด  
50/23 หมู่ 3 ต.มหาสวัสดิ์ อ.บางกรวย จ.นนทบุรี 11130  
Tel : 02 105 4676  
Fax : 02 903 0080 ext. 6867  
Email : info@omi.co.th