

BA16

www.omi.co.th

EN

OPERATING MANUAL
ANEMOMETER

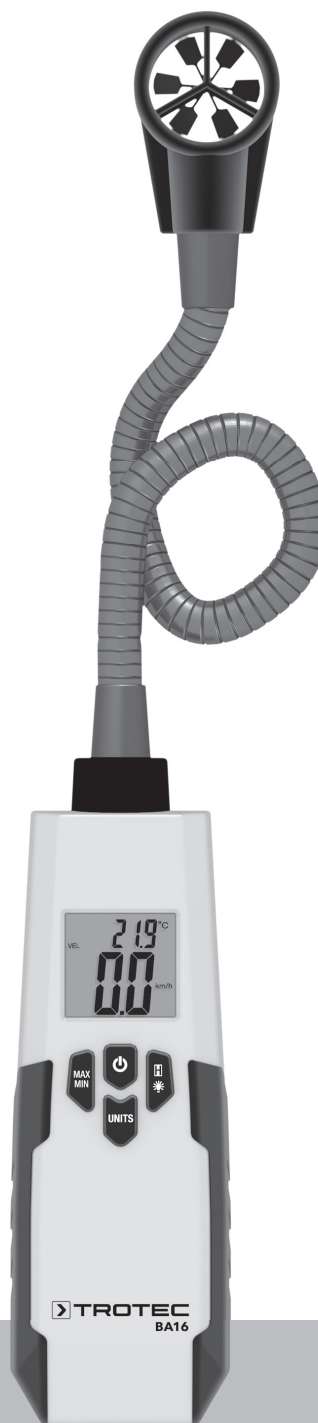



Table of contents

Notes regarding the operating manual 1
 Information about the device 1
 Technical data 2
 Safety 3
 Transport and storage 3
 Operation 4
 Maintenance and repair 5
 Disposal 5
 Declaration of conformity 5

Notes regarding the operating manual

Symbols

Danger!
 Warns of a hazard which can lead to injuries.

Caution!
 Warns of a hazard which can lead to damage to property.

The current version of the operating manual can be found at:
www.trotec.de

Legal notice

This release replaces all previous versions. No part of this publication may be reproduced without written permission from TROTEC®. The same applies for electronically processing, duplicating or spreading the publication. Subject to technical changes. All rights reserved. Trademarks are used without guarantee that they may be used freely and primarily following the spelling of the manufacturer. Product names are registered. Changes to construction in the interests of constant improvements to the product, as well as changes to the shape and colour are reserved.

The scope of delivery may vary from product images. This document was created with all due care. TROTEC® accepts no liability whatsoever for possible mistakes or omissions.

The only party responsible for determining measured results to be valid, drawing conclusions and deriving actions is the user! TROTEC® accepts no claims of warranty for the correctness of the determined measured values or measured results. Further, TROTEC® accepts no liability whatsoever for possible mistakes or damage which have been caused by utilising the determined measured results. © TROTEC®

Information about the device

Description of the device

The anemometer BA16 can simultaneously measure the temperature and air velocity.

Temperature measuring is effected by means of an integrated thermistor in °C or °F.

The air velocity can be indicated in the following units:

- m/s
- km/h
- ft/min
- mph
- knots
- m³/min (CMM)

The sensor is located at a so-called gooseneck probe, with that it is able to measure even in poorly accessible locations.

Further available for the assessment of the measurements are a Hold and a Max/Min function.

The display illumination can be switched on as needed.

When not in use, an automatic switch-off saves the battery.

Device depiction

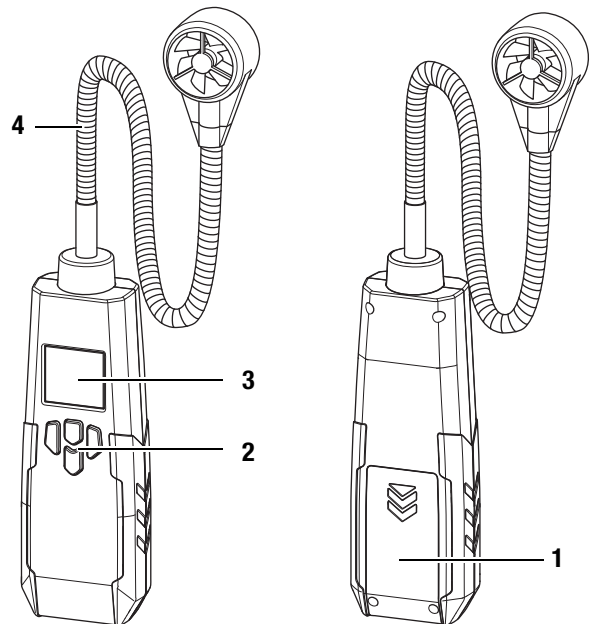

No.	Operating element
1	Battery compartment with cover
2	Operating elements
3	Display
4	Measuring sensor with flexible holder

Operating elements

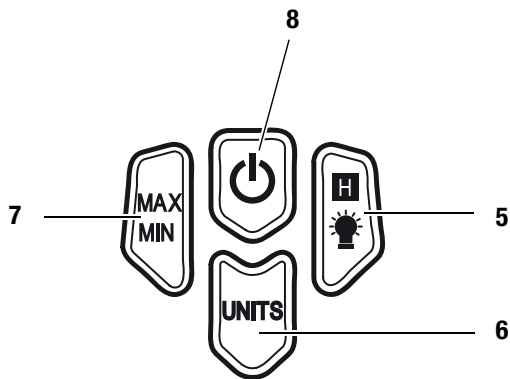

No.	Operating element
5	HOLD/lamp button
6	UNITS key
7	Max/Min button
8	On/Off key

Display

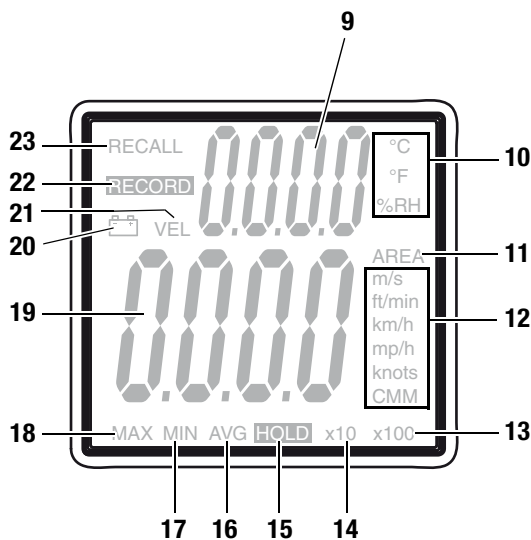

No.	Display element
9	Indication of the measured temperature value
10	Indication of the temperature unit
11	AREA indication
12	Indication of the units for velocity and volumetric flow
13	Indication of the measured value x 100
14	Indication of the measured value x 10
15	HOLD indication
16	AVG indication
17	MIN indication
18	MAX indication
19	Indication of the measured velocity value
20	Battery indication
21	VEL indication
22	RECORD indication
23	RECALL indication

Technical data

Model:	BA16
Weight:	approx. 270g
Dimensions (H x W x D):	162 mm x 54 mm x 32 mm
Length of the gooseneck probe:	360 mm
Air current	
Measuring range:	0-999.9 m ³ /min CMM
Resolution:	0.1 CMM
Effective range:	0-999.9 m ²
Air flow rate	
Measuring range:	1.00 to 30.00 m/s 196 to 5900 ft/min 3.6 to 108.0 km/h 2.2 to 67.0 mph 1.9 to 58.0 kn
Resolution:	0.01 m/s 1 ft/min 0.1 km/h 0.1 mph 0.1 kn
Accuracy:	± 3 %; ± 0.20 m/s ± 3 %; ± 40 ft/min ± 3 %; ± 0.8 km/h ± 3 %; ± 0.4 mph ± 3 %; ± 0.4 kn
Temperature	
Measuring range:	-10 to 60 °C (14 to 140 °F)
Accuracy:	±1.5 °C (3.0 °F)
Measuring range resolution:	0.1 °C (0.1 °F)
Operating temperature:	0 to 50 °C (32 to 122 °F)
Relative humidity for operation:	max. 80 % RH
Storage temperature:	-20 to 60 °C (-4 to 140 °F)
Relative humidity for storage:	< 80 % RH
Power supply:	1 x 9 V battery
Automatic switch-off of the device:	After approx. 15 minutes of non-use

Scope of delivery

- 1 x Anemometer BA16
- 1 x 9 V battery
- 1 x Getting started guide

Safety

Carefully read the operating manual before using the device and keep it within reach!

- Do not use the device in atmospheres containing oil, sulphur, chlorine or salt.
- Protect the device from permanent direct sunlight.
- Do not remove any safety signs, stickers or labels from the device. Keep all safety signs, stickers and labels in legible condition.
- Observe the storage and operating conditions (see chapter Technical data).

Intended use

Only use the device for air velocity measurements within the measuring range specified in the technical data.

Here, read and observe the technical data.

To use the device for its intended use, only use accessories and spare parts which have been approved by TROTEC®.

Improper use

Do not use the device in potentially explosive atmospheres, for measurements in liquids and at live parts. TROTEC® accepts no liability for damages resulting from improper use. In such a case, entitlements to a warranty are forfeited. Any unauthorised modifications, alterations or structural changes to the device are forbidden.

Personnel qualifications

People who use this device must:

- have read and understood the operating manual, especially the Safety chapter.

Residual risks



Danger!

Do not leave the packaging lying around. Children may use it as a dangerous toy.



Danger!

The device is not a toy and does not belong in the hands of children.



Danger!

Dangers can occur at the device when it is used by untrained people in an unprofessional or improper way. Observe the personnel qualifications.



Caution!

To prevent damages to the device, do not expose it to extreme temperatures, extreme humidity or moisture.



Caution!

Do not use abrasive cleaners or solvents to clean the device.

Transport and storage

Transport

For transporting the device use a suitable bag to protect it from external influences.

Storage

When the device is not being used, observe the following storage conditions:

- dry.
- protected from dust and direct sunlight.
- with a plastic cover to protect it from invasive dust, if necessary.
- The storage temperature is the same as the range given in the chapter Technical data.
- When storing the device for a long time, remove the batteries.

Operation

Inserting the batteries



Caution!

Make certain that the surface of the device is dry and the device is switched off.

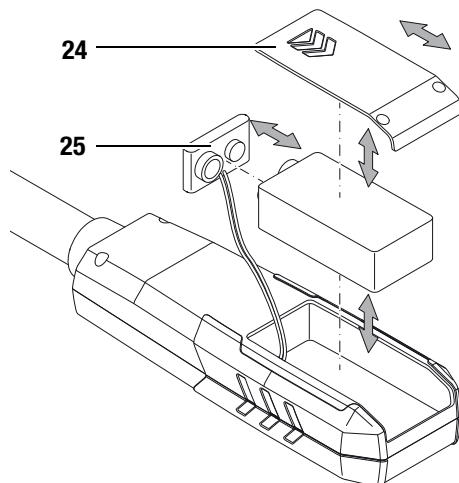

1. Remove the cover (24) from the device by sliding it in the direction of the arrow.
2. Use the battery clip (25) to connect the new battery with correct polarity.
3. Slide the cover (24) back on the device.

Switch-on and measurements

1. Press the On/Off key (8) for approx. 3 seconds.
 - The display is switched on and the device is ready for operation.
2. Point the device at the area to be measured.
 - The measured values for temperature and air velocity are displayed in real time.

Note:

Note that moving from a cold area to a warm area can lead to condensation forming on the device's circuit board. This physical and unavoidable effect can falsify the measurement. In this case, the colour display shows either no measured values or they are incorrect. Wait a few minutes until the device has become adjusted to the changed conditions before carrying out a measurement.

Switching the display illumination on and off

1. Press the HOLD/lamp button (5) for approx. 2 seconds.
 - The display illumination goes on.
2. Press the HOLD/lamp button (5) again for approx. 2 seconds.
 - The display illumination switches off.

Setting the temperature unit

- Press the UNITS key (6) for approx. 3 seconds.
 - Depending on the setting the temperature indication (10) changes to °C or °F.

Setting the air velocity unit

- Press the UNITS key (6) until the desired unit is displayed.

Setting the AREA

In order to measure the volumetric flow (CMM) as accurately as possible, the area of the opening to be tested should be specified. The AREA's unit is m².

1. Switch off the device.
2. Press and hold the HOLD/lamp button (5) while switching the device back on.
 - The indication SET AREA will be appear on the display.
3. Press the MAX/MIN button (7).
 - The decimal point will move.
4. Press the HOLD/lamp button (5).
 - You can alternate between the digits, the selected number flashes.
5. Press the UNITS key (6).
 - The value of the selected digit changes.
6. Repeat the steps 5. and 6. until the value is set as desired.
7. Switch off the device.
 - The set AREA value will be used for the calculation of the volumetric flow after the next switch-on.

Setting the MAX/MIN function

1. Press the MAX/MIN button (7).
 - RECORD appears on the display.
2. Press the MAX/MIN button (7) to switch between MIN and MAX.
 - The highest or lowest value will be displayed.
3. Press the MAX/MIN button (7) for approx. 3 seconds to terminate the function.
 - The values will be deleted.

Setting the HOLD function

1. Press the HOLD/lamp button (5).
 - The current value will be held.
2. Press the HOLD/lamp button (5) again.
 - The display again indicates the current measured value.

De-/activating automatic switch-off

- Switch the device on.
 - Automatic switch-off (after 15 minutes) is activated.
- Additionally press the UNITS key (5) when switching the device on.
 - The indication *disAPO* appears on the display.
 - Automatic switch-off (after 15 minutes) is deactivated (auto power off disabled).

Switch-off

1. Press the on/off key (8).
 - The device will be switched off.
 - The MAX and MIN values are reset.

Maintenance and repair

Battery change

A battery change is required, when the Battery indication (20) lights up in the display or the device can no longer be switched on. See Inserting the batteries on page 4.

Cleaning

Clean the device with a soft, damp and lint-free cloth. Ensure that no moisture enters the housing. Do not use any sprays, solvents, alcohol-based cleaning agents or abrasive cleaners. Only use clean water to moisten the cloth.

Repair

Do not modify the device. Never open the device housing or install any spare parts. For repairs or device testing, contact the manufacturer.

Disposal



In the European Union, electronic equipment must not be treated as domestic waste, but must be disposed of professionally in accordance with Directive 2002/96/EC of the European Parliament and Council of 27th January 2003 concerning old electrical and electronic equipment. At the end of its life, please dispose of this instrument in a manner appropriate to the relevant legal requirements.

Declaration of conformity

in accordance with the EC Low Voltage Directive 2006/95/EC and the EC Directive 2004/108/EC about electromagnetic compatibility.

Herewith, we declare that the anemometer BA16 was developed, constructed and produced in compliance with the named EC directives.

The $\text{C} \in$ marking is found on the rear of the device.

Manufacturer:
Trotec GmbH & Co. KG
Grebbeener Straße 7
D-52525 Heinsberg

Phone: +49 2452 962-400
Fax: +49 2452 962-200
E-mail: info@trotec.com

Heinsberg, 31/03/2014

Managing Director: Detlef von der Lieck

Trotec GmbH & Co. KG

Grebener Str. 7
D-52525 Heinsberg

บริษัท โอเมก้า เมชเชอริง อินสตรูमेंท์ จำกัด
50/23 หมู่ 3 ต.มหาสวัสดิ์ อ.บางกรวย จ.นนทบุรี 11130
Tel : 02 105 4676
Fax : 02 903 0080 ext. 6867
Email : info@omi.co.th