

Sensor TA10 ... ZG1b (li.) for use with suitable transducers and handheld units

Measurable variable

- standard velocity N_v , standard volume flow NV/t , mass flow proportional
- standard basis adjustable, default:
temperature $t_n = +21\text{ °C}$, pressure $p_n = 1014\text{ hPa}$
- temperature t
(handheld flowtherm Ex, flowtherm NT, HTA, HTA-Ex)

Functional principle

- measurement of flow according to the thermal measuring method (heat transfer method)

Design

- probe

Advantages

- high measuring dynamics N_v (up to 1 : 1000)
- small starting value: 0.2 m/s
- low measuring uncertainty, even at lowest flow velocities
- direct air/gas mass flow-proportional measuring, largely irrespective of working pressure and temperature
- sensor has no moving parts
- sensor housing made of stainless steel
- greater working temperature and pressure ranges
- high time yield
- corrosion resistant
- lower pressure drop due to small dimensions

Medium

- clean gases, gas mixtures: air, nitrogen, methane, natural gas, argon, carbon dioxide, helium, sulphur hexafluoride, landfill gas ...

Range and examples of application

- Air flow measurements
- Portable and stationary application
- compressed air and gas consumption and leakage measurements
- measuring
 - laminar flows in clean rooms or machines
 - in outgoing air, burner supply air and draughts
 - in climatic applications
 - in air in the rough vacuum range with pressures greater than 200 hPa abs.

Particles, condensation, humidity in the gas

- Charges in the gas caused by particles such as dust and fibres do not affect the measurement, as long as abrasion and agglomeration do not occur on the sensor
- relative gas humidity of less than 100 % does not affect the measuring uncertainty if the working temperatures are less than +40 °C

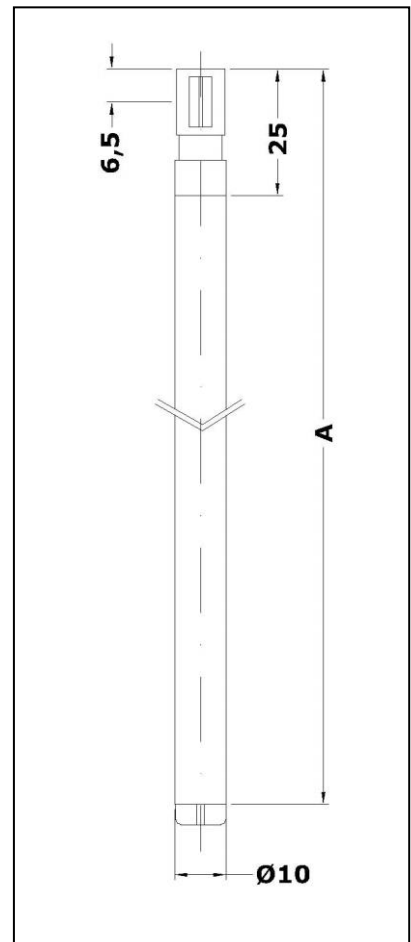

Probe TA10 ... ZG1b
(Meas. A see Page 2)

Model designation / Order code (example)							
TA10	-185	G	E	140	p16	Ex	ZG1b
(1)	(2)	(3)	(4)	(5)	(6)	(7)	(8)

Basic types	
Type	Article No.
TA10- 185 GE 140 / p16 ZG1b	B013/300
TA10- 285 GE 140 / p16 ZG1b	B013/301
TA10- 385 GE 140 / p16 ZG1b	B013/302
TA10- 685 GE 140 / p16 ZG1b	B013/303

(1) Sensor type / Probe diameter	
Thermal flow sensor, epoxy resin coated thin-film sensor element	
Probe diameter 10 mm	

(2) Sensor length measurement A	
Standard length (see Basic types)	185, 285, 385, 685 mm
Fix sensor length based on	required insertion depth in the measurement cross section, sleeve or muff length, length of ball valve and length of probe guide piece (see Accessories)

(3) Medium	
Air, clean gases, gas mixtures with ratio of mixture consistent	
When calibrating/justifying sensor and evaluation unit for gases other than air the slightest possible measuring uncertainty is only achievable by ensuring fixed allocation of sensor to evaluation unit.	

(4) Materials in contact with the medium	
Stainless steel 1.4571, 1.4305, glass, epoxy resin	

Measuring ranges	
	Article No.
0.2 ... 30 m/s	V_TA10_1B_30
0.2 ... 60 m/s	V_TA10_1B_60
0.2 ... 120 m/s	V_TA10_1B_120
0.2 ... 150 m/s	V_TA10_1B_150
0.2 ... 180 m/s	V_TA10_1B_180
0.2 ... 200 m/s	V_TA10_1B_200

Examples – measurable volume flows								
meas. tube inside diameter Di [mm]	profile factor PF* [-]	smallest measurable value [Nm ³ /h]	measuring range terminal values [Nm ³ /h]					
			sensor measuring range					
			'30 m/s'	'60 m/s'	'120 m/s'	'150 m/s'	'180 m/s'	'200 m/s'
25	0.725	0.26	39	77	154	192	231	256
40	0.810	0.73	110	220	440	550	660	730
50	0.840	1.2	178	356	713	890	1070	1180
60	0.840	1.7	257	513	1030	1280	1540	1710
80	0.840	3.0	456	912	1820	2280	2740	3040
100	0.840	4.8	713	1425	2850	3560	4280	4750
120	0.840	6.8	1026	2050	4100	5130	6160	6840
150	0.840	11	1600	3210	6410	8020	9620	10600
200	0.840	19	2850	5700	11400	14250	17100	19000
300	0.840	43	6410	12820	25650	32060	38480	42750
400	0.840	76	11400	22800	45600	57000	68400	76000
500	0.840	120	17800	35600	71200	89100	106900	118800
1000	0.840	480	71200	142500	285000	356300	427600	475000

Standard volume flow measuring range specifications with centric positioning of the sensor, irrotational afflux and amply-dimensioned input and output section (see Instruction Manual).

* The profile factor PF describes the ratio of average flow velocity in the measurement cross section and the flow velocity measured from the sensor. The afore-mentioned operating conditions apply.

Measuring uncertainty / Time constant	
Measuring uncertainty for flow velocity Nv	
less than/equal to 40 m/s	: 2 % of test value + 0.02 m/s
greater than 40 m/s	: 2.5 % of test value
Time constant	: in seconds

(5) Permissible temperature of the medium
-10 ... +140 °C

(6) Maximum working pressure
up to 16 bar / 1.6 MPa above atmospheric
higher working pressures on request

(7) Option Ex-protection	
Design	Article No.
Ex ib IIC T4 Gb Category 2G (Zone 1) necessary when using with flowtherm Ex, HTA-Ex	TA10_1B_EX1
Ex ia IIC T4 Ga/Gb Category 1/2G (Zone 0/1) necessary when using with U15-Ex	TA10_1B_EX0
Ex nA IIC T4 Gc X in combination with suitable transducer or handheld unit Ex tc IIIC T135°C Dc X Kategorie 3D (Zone 22) in combination with suitable transducer	TAEX2

(8) Design
Probe; as in Drawing ZG1b (see Page 1)

Connection cable / Connection

standard sensor connection cable length 3 m, direct outlet, resistant up to +140 °C, other cable lengths on request.

If cable lengths deviate from the norm the smallest possible measuring uncertainty is only available, if sensor and evaluation unit have a fixed allocation.

connection (IP67) for

transducer U10a, handhelds flowtherm Ex, flowtherm NT, HTA : plug 423-5 with gilded contacts

transducer U15-Ex, handheld HTA-Ex : plug 423-8 with gilded contacts

Ingress protection / Fitting position

Ingress protection: Sensor IP68; cable outlet IP65

Any fitting position with atmospheric pressure, with pressures above atmospheric direction of flow not from above

Elektromagnetic compatibility (EMC)

IEC 1000-4, EN 61000

Necessary compatible, separate evaluation units

for non-Ex applications

- transducer U10a
- handheld HTA
- flowtherm NT

for Ex applications

- transducer U15-Ex
Ex nA [ia] IIC T4 Gc Category 3(1)G
- handheld HTA-Ex
Ex ia IIC T4 Gb Category 2G (Zone 1)
- handheld flowtherm Ex
Ex ib IIC T4 Gb Category 2G (Zone 1)

Accessories		
	Description	Article No.
	Calibration certificate	KLB
Drawing 5 probe guide piece SFB 10 E-35 / G 1/2" ZG5	min. 6 standard calibration values for any repeated positioning with lower overpressure (max. 3 bar) / underpressure for connecting to screw socket or ball valve with inside thread G 1/2", threaded height 22 mm, working temperature range -20 ... +240 °C, installation length 35 mm, materials: stainless steel, VITON®, PTFE clamping bush	B004/503
Drawing 6 probe guide piece SFB 10 E-60 / G 1/2" ZG6 with clamp clip and anti-twist device	for any repeated positioning with higher overpressure / underpressure, clamping device for safeguarding the probe attachment, for connecting to screw socket or ball valve with inside thread G 1/2", working temperature range -20 ... +240 °C, installation length 55mm, materials: stainless steel, VITON®, PTFE clamping bush	B004/600
Drawing 7 probe guide piece SFB 10 E-60 / G 1/2" ZG7 with chain guard, clamp clip and anti-twist device	for any repeated positioning with higher overpressure / underpressure, clamping device for safeguarding the probe attachment and chain guard, for connecting to screw socket or ball valve with inside thread G 1/2", working temperature range -20 ... +240 °C, installation length 55mm, materials: stain-less steel, VITON®, PTFE clamping bush	B004/601

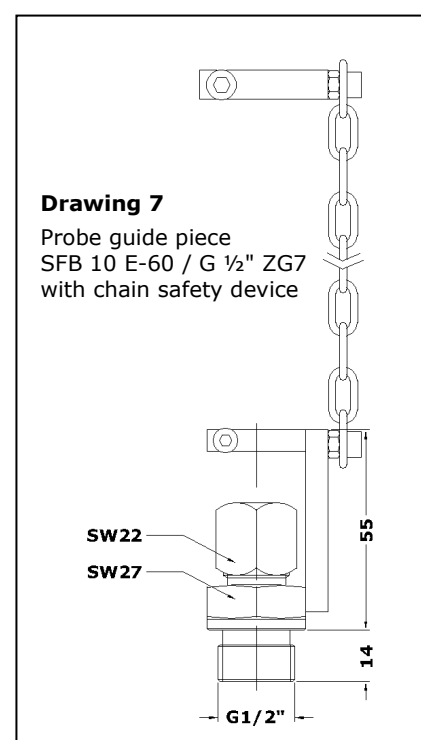
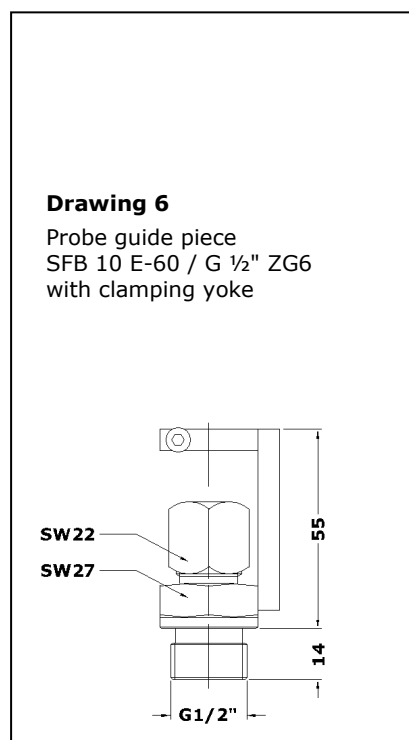
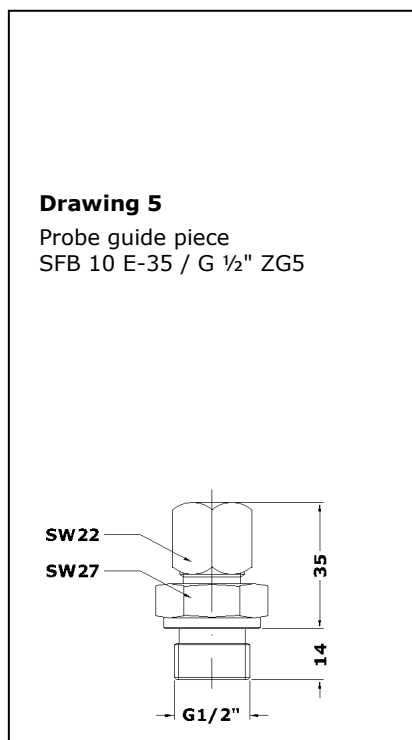

Accessories (cont.)		
	Description	Article No.
Direction indicator RZ10	for recognition of direction of flow and insertion depth, adjustable, suitable for sensor TA10 with 10 mm diameter	B099/948
HG10/18A-130	handle with collet chuck suitable for TA10...ZG1b as well as extion tubes VS18, not impervious	B099/947
VS18A-350	aluminium extension rod, with screw thread, Ø 18 mm, 350 mm long, O-ring seal VITON [®] , working temperature range -25 ... +240 °C	B099/010
Direction indicator RZ18	for recognition of direction of flow and insertion depth, adjustable, suitable for extension rods with 18 mm diameter	B099/951
Ball valve	installation length 75 mm, through hole 15 mm, material stainless steel 1.4408, seal PTFE, working temperature range max. +200 °C, max. working pressure 64 bar/6.4 MPa rel., inside connection thread G 1/2" (DIN/ISO 228)	B004/900

Höntzsch GmbH

Gottlieb-Daimler-Straße 37
 D-71334 Waiblingen (Hegnach)
 Telefon +49 7151 / 17 16-0
 Telefax +49 7151 / 5 84 02
 E-Mail info@hoentzsch.com

จัดจำหน่ายโดย

บริษัท โอเมก้า เมชเชอริง อินสตรูเมนต์ จำกัด
 50/23 หมู่ 3 ต.มหาสวัสดิ์ อ.บางกรวย จ.นนทบุรี 11130
 Tel : 02 105 4676
 Fax : 02 903 0080 ext. 6867
 Email : info@omi.co.th

® : Registered trade mark
 of DuPont