

Micaflex PU3.
Purging unit for flow sensor controlled with
MF-PFTT and PFA-PU ver 3

MF-PU3
ver 3.x

Application

MicaFlex PU3 is designed to be used with Micatrone transmitter type MicaFlex PFTT or PFA-PU ver 3 to prevent a connected flow sensor or pressure tap from clogging in applications where the measured air flow is polluted or an increased risk of condensation is present.

The transmitter control the purging units solenoid valves. The purging interval can be set between 30 and 3600 seconds and every purging period can be set between 0 and 60 seconds. During purging, the output signal from the transmitter is frozen to avoid interference in the measurement.



Design

MicaFlex PU3 consists of two solenoid valves and a control board with terminals. The purging function is activated by the control signal from the transmitter. All pressure connections are made on the outside of the enclosure.

Function

During the pause period, the flow sensor or pressure tap is connected to the MF-PFTT/PFA-PU. During the purging period, two valves inside the unit close the connection to the MF-PFTT/PFA-PU and opens the connection for the compressed air inlet to clean the flowsensor or pressure tap.

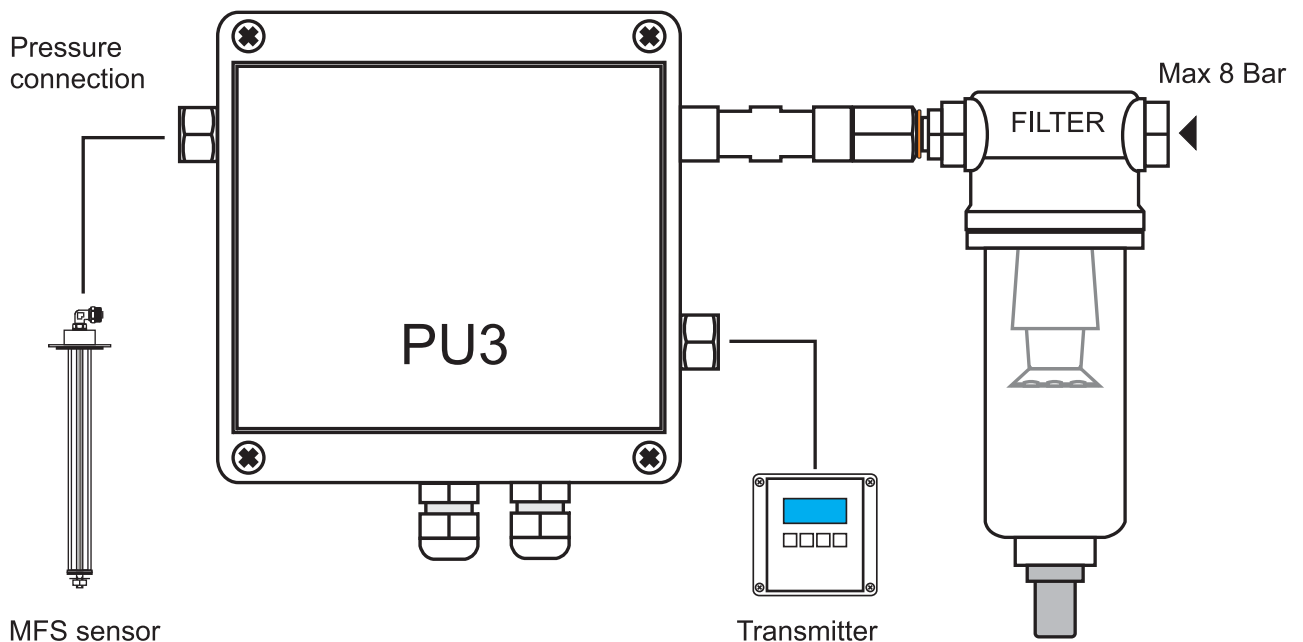

Technical data

Supply voltage: 24VAC 50/60 Hz or 24VDC.
 Power consumption: 25 VA
 Control signal: 10 Volt or 20 mA
 Compressed air: 6...8 Bar, filtered
 Pres. connections for:
 Transmitter/Sensor: G1/8" internal thread.
 Fittings for 8/6 mm tube or 6 mm Cu pipe is included, must be stated when ordering
 Compressed air: G1/8" internal thread
 Dimensions [WxHxD]: 120 x 122 x 90 mm (enclosure only)

Warning:

Due to risk of a stored compressed air volume in tube between flow sensor and purging unit when valve shift from purging to normal operation, the length must not exceed 5 metre between flow sensor and purging unit to avoid overload and risk of damage to the transmitter.

Valve function in purging mode and normal mode:

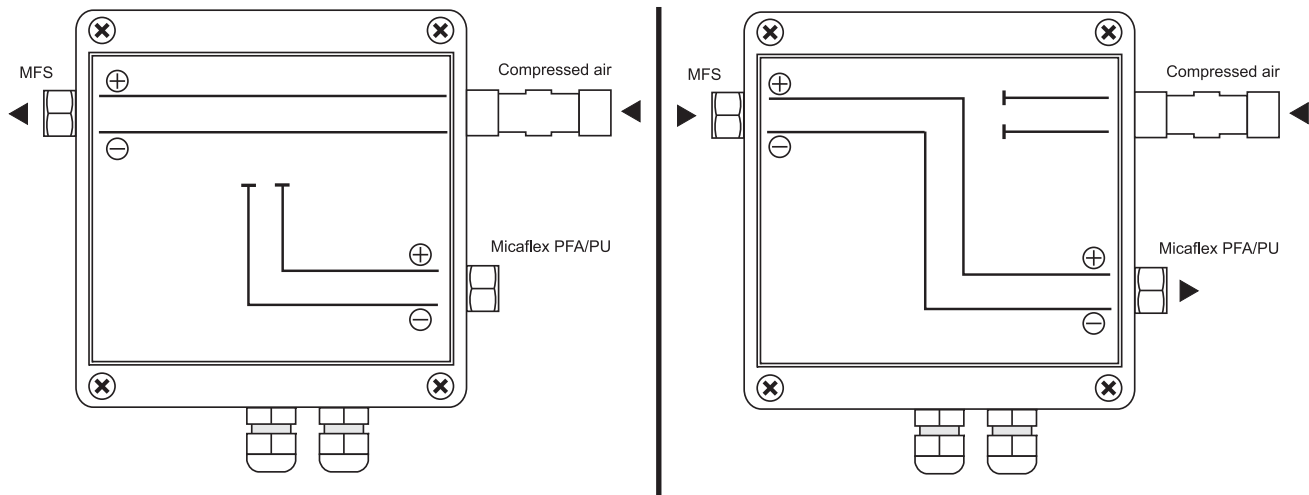

Electrical connection:

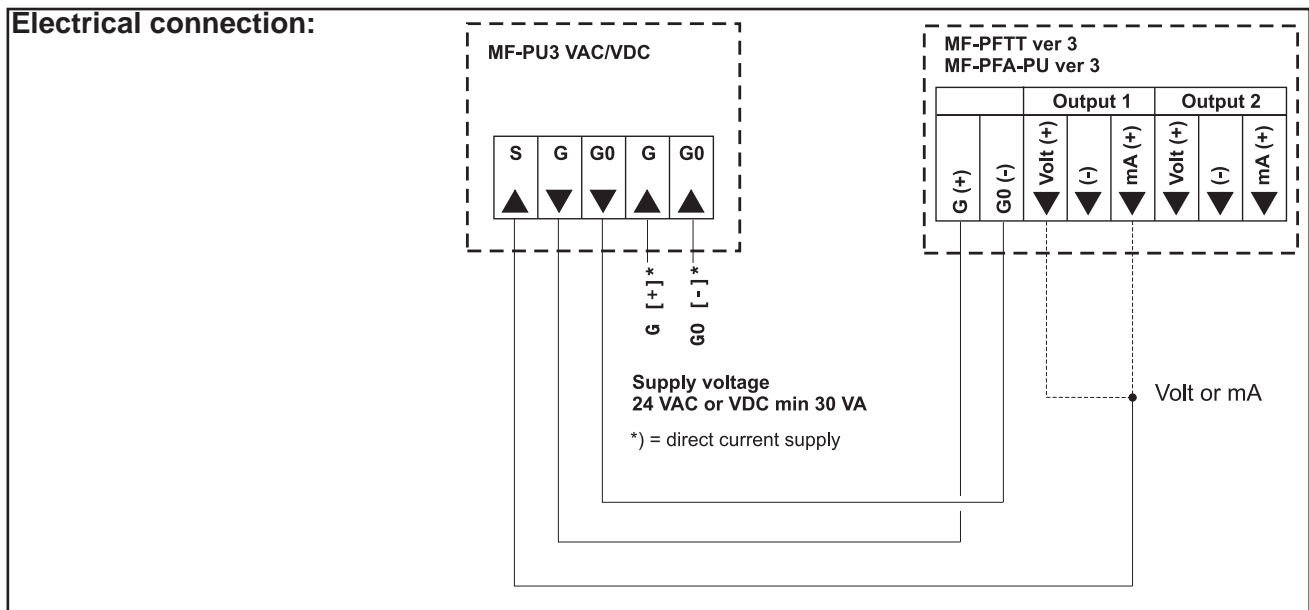

AB Micatrone
 Aldermansvagen 3
 SE-171 48 SOLNA
 SWEDEN

Telephone: +46-8-470 25 00

Internet: www.micatrone.se
E-mail: info@micatrone.se