

**Vortex flow sensor, extendable,
 optional with integrated PT100 sensor,
 for connection to a fixed or portable evaluation unit**

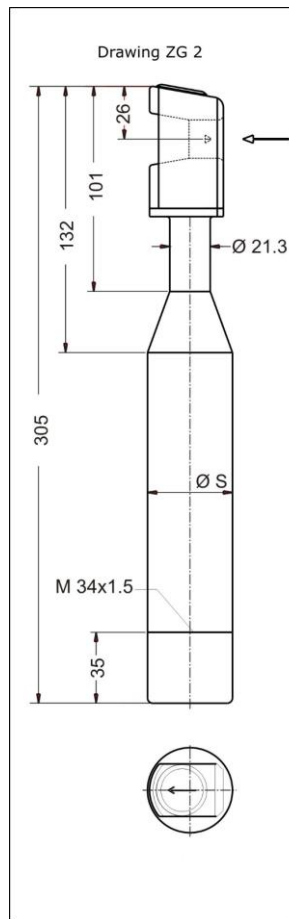

probe VA(T)40/42 ZG2



Range and examples of application

- permanent and portable
- flow measurement e.g. of air, exhaust air or gas, process gas
- in heavily contaminated gases
- in processes with changing and/or unknown gas composition
- in moist gases or gases that are partly liable to condensate
- waste incineration plants
- large combustion plants
- monitoring of inerting processes
- use up to 240 °C
- recommended according DIN EN ISO 16911, normative for checking of automatic measuring equipment

Advantages

- no moving parts
- long-term stability
- high durability
- corrosion-resistant
- easy to clean
- marginal pressure loss
- exact measuring values even at changing and/or unknown gas composition
- high turn down ratio (1:80)
- no distortion of the measurement values by thermal radiation
- optional for use in category 2G (zone 1)
- extendable
- universal range of use
- optional with integrated PT100 sensor
- suitable for big stacks, pipes and ducts

Functional principle

- vortex meter for measuring flow velocity, flow rate and volume
- ultrasonic measurement of the vortex shedding



Kármán vortex street

Measuring range

- 0.5 ... 60 m/s

Design

- insertion probe with fixed cable, extendable

Medium

- primarily single-phase gas mixtures, e.g. air, nitrogen, oxygen, methane, natural gas, ammonia, argon, carbon monoxide, superheated steam, biogas, exhaust gas, etc.
- other gases or gas mixtures on request

Measured variables

- actual flow velocity v [m/s]
- actual flow rate [m³/h]
- optional temperature [°C]
- conversion to standard velocity/standard volume flow with input parameters pressure and temperature

Connection possibilities

- portable and fixed evaluation units with sensor input

Particles, humidity and condensation

- dust or fibre particles in the gas do not affect the measurement, as long as these are not abrasive or accumulate on the sensor
- measurement uncertainty remains unaffected by a relative gas humidity of less than 100 % and a slight accumulation of condensate on the sensor

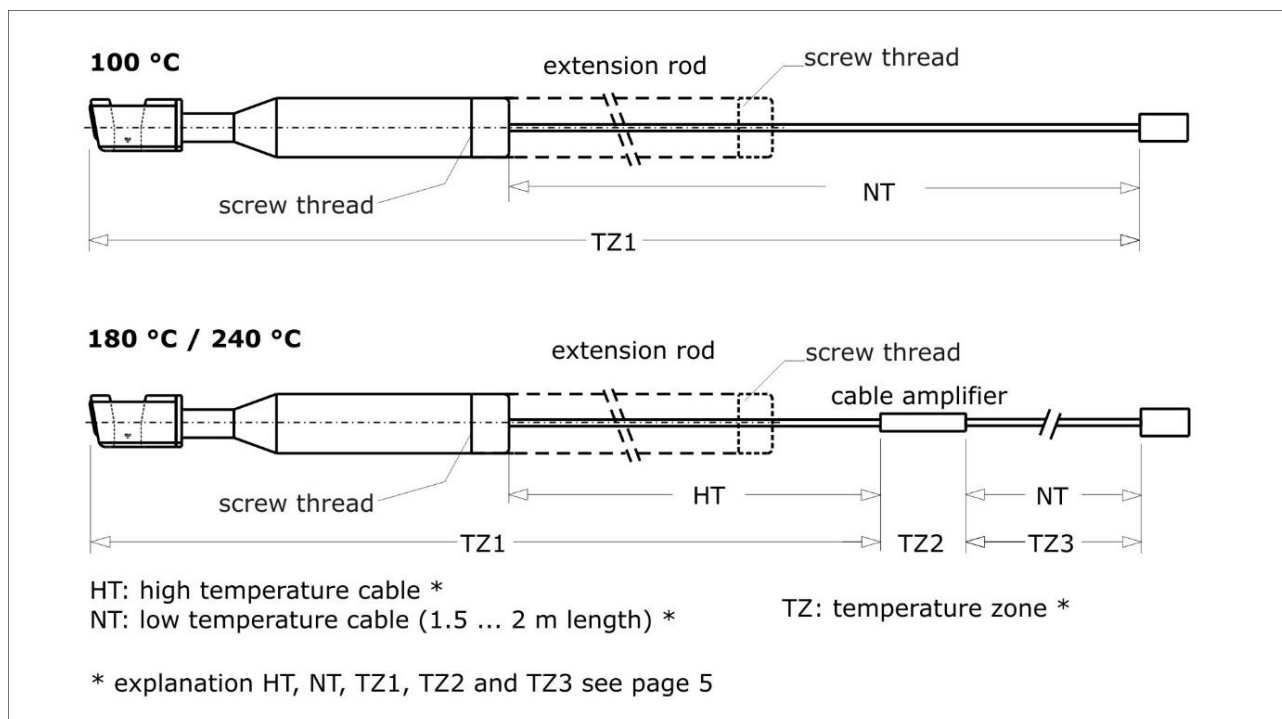

Model designation (example)										
VA	40	/42	G	E	40 m/s	240	-2	p3	ZG2	
VAT	40	/42	G	E	60 m/s	180	-3	p3	ZG2	
VA	40	/42,4	G	H	40 m/s	100		p3	ZG2	KALREZ
VA	40	/42	G	T	40 m/s	100		p3	ZG2	
(1)	(2)	(3)	(4)	(5)	(6)	(7)	(8)	(9)	(10)	(11)

Types										
type										article no.
VA	40/42	GE	40 m/s	100	/	p3	ZG2			B009/200
VA	40/42,4	GH	40 m/s	100	/	p3	ZG2			B009/208
VA	40/42	GT	40 m/s	100	/	p3	ZG2			B009/212
VA	40/42	GE	40 m/s	180-2	/	p3	ZG2			B009/216
VA	40/42,4	GH	40 m/s	180-2	/	p3	ZG2			B009/222
VA	40/42	GT	40 m/s	180-2	/	p3	ZG2			B009/226
VA	40/42	GE	40 m/s	240-2	/	p3	ZG2			B009/230
VA	40/42,4	GH	40 m/s	240-2	/	p3	ZG2			B009/231
VA	40/42	GT	40 m/s	240-2	/	p3	ZG2			B009/232
VAT	40/42	GE	40 m/s	100	p3	ZG2				B009/250
VAT	40/42,4	GH	40 m/s	100	p3	ZG2				B009/258
VAT	40/42	GT	40 m/s	100	p3	ZG2				B009/262

Types (cont`d)			type	article no.
VAT 40/42	GE	40 m/s 180-2 / p3 ZG2		B009/266
VAT 40/42,4	GH	40 m/s 180-2 / p3 ZG2		B009/272
VAT 40/42	GT	40 m/s 180-2 / p3 ZG2		B009/276
VAT 40/42	GE	40 m/s 240-2 / p3 ZG2		B009/280
VAT 40/42,4	GH	40 m/s 240-2 / p3 ZG2		B009/281
VAT 40/42	GT	40 m/s 240-2 / p3 ZG2		B009/282
design with KALREZ® sealings				
VA 40/42	GE	40 m/s 100 / p3 ZG2 KALREZ		B009/205
VA 40/42,4	GH	40 m/s 100 / p3 ZG2 KALREZ		B009/210
VA 40/42	GT	40 m/s 100 / p3 ZG2 KALREZ		B009/214
VA 40/42	GE	40 m/s 180-2 / p3 ZG2 KALREZ		B009/220
VA 40/42,4	GH	40 m/s 180-2 / p3 ZG2 KALREZ		B009/224
VA 40/42	GT	40 m/s 180-2 / p3 ZG2 KALREZ		B009/228
VAT 40/42	GE	40 m/s 100 p3 ZG2 KALREZ		B009/255
VAT 40/42,4	GH	40 m/s 100 p3 ZG2 KALREZ		B009/260
VAT 40/42	GT	40 m/s 100 p3 ZG2 KALREZ		B009/264
VAT 40/42	GE	40 m/s 180-2 / p3 ZG2 KALREZ		B009/270
VAT 40/42,4	GH	40 m/s 180-2 / p3 ZG2 KALREZ		B009/274
VAT 40/42	GT	40 m/s 180-2 / p3 ZG2 KALREZ		B009/278

(1) Sensor type

Description	Design
VA	vortex flow sensor
VAT	vortex flow sensor with integrated PT100 sensor

(2) Sensor diameter

vortex width across corners	
40	vortex flow sensor VA40 with sensor head width across corners 40 mm for insertion in openings with a diameter greater than 44 mm

(3) Shaft diameter

shaft diameter of the sensors \emptyset S (s. page 1, drawing ZG2)	
/42	shaft diameter 42 mm
/42,4	shaft diameter 42.4 mm

(4) Medium

... G ...	air/gases
-----------	-----------

Ingress protection cable outlet

sensor design ... G ...	IP50
-------------------------	------

(5) Materials in contact with the medium

design	material
... E ...	stainless steel, sensor housing 1.4581 shaft 1.4404, ceramics, FKM or KALREZ® seals, silicone-free sensor
... H ...	Hastelloy 2.4610 / HC4, ceramics, FKM or KALREZ® seals, silicone-free sensor
... T ...	titanium 3.7035 (grade 2), ceramics, FKM or KALREZ® seals, silicone-free sensor
other sealing materials on request	

(6) Measuring range

design	measuring range
... 40 m/s ...	0.5 ... 40 m/s
... 60 m/s ...	0.7 ... 60 m/s (on request)

Measurement accuracy * < 1.0 % of measured value + 0.03 m/s **

Repeatability * ± 0.2 % of measured value + 0.025 % of terminal value

The lowest measurement uncertainties in the field are attained with calibrations as close as possible to the operating conditions. For this, the measurement results obtained can be implemented as characteristic in the evaluation unit. Information and details on the measurement uncertainties according to the calibrated measurement standards can be found in the calibration documents 'U325 and U183'.

* only for versions with pairs of values with linearization of characteristics and for sensor design up to 40 m/s; by use of KKZ-function other specification are possibly valid

** related to calibration conditions on the Höntzsch wind tunnel WK320

Profile factors depending on pipe inside diameter

measuring tube inside diameter Di [mm]	profile factor PF* [-]	measuring tube inside diameter Di [mm]	profile factor PF* [-]
80	0.719	300	0.845
100	0.738	400	0.850
120	0.761	500	0.860
150	0.796	...	0.860
200	0.842	peculiarity ^o	1.000

* These profile factors are only accurate with centric sensor positioning, turbulent, non-rotational inlet flow and sufficiently dimensioned input and output sections (see Operating Instructions). The profile factor describes the ratio of average flow velocity in the measurement cross section area and the flow velocity measured from the sensor. The above mentioned operating conditions apply.

^o With profile factor 1.000, the local flow velocity at the sensor head will be passed on without further calculation.

(7, 11) Permissible temperatur of the medium / ambient temperature / sealing

design	temperature of the medium	ambient temperature (see drawings, page 2)		
FKM		TZ1	TZ2	TZ3
... 100 ...	-20 ... +100 °C	-20 ... +100 °C	-	-
... 180 ...	-20 ... +180 °C	-20 ... +180 °C	-40 ... +125 °C	-40 ... +125 °C
... 240 ...	-20 ... +240 °C	-20 ... +240 °C	-40 ... +125 °C	-40 ... +125 °C
KALREZ®		TZ1	TZ2	TZ3
... 100 ...	0 ... +100 °C	0 ... +100 °C	-	-
... 180 ...	0 ... +180 °C	0 ... +180 °C	-40 ... +125 °C	-40 ... +125 °C

The temperature ranges may differ when using other sealing materials.

(8) Cable lengths of high temperature cable (HT-cable) in front of cable amplifier

design	description
for sensor design up to 180 °C and 240 °C*	
... -2 ...	2 m fixed high temperature cable in front of cable amplifier * + 1.5 m silicone cable (NT-cable, max. +125 °C) behind cable amplifier *

* special cable lengths for HT-cable in front of the cable amplifier and standard cable (NT-cable) behind cable amplifier on request

(9) Maximum working pressure

... p3 ...	up to 3 bar / 0.3 MPa overpressure
------------	------------------------------------

(10) Design

as in drawing 2 (page 1)

Electromagnetic Compatibility (EMC)

according to EN 61 000-6-2 and EN 61 000-6-4

Installation position

any	horizontal positioning is recommended if condensate on the sensor cannot be ruled out
-----	---

Option ATEX-protection

type of protection	art. no.	comment
CE <Ex> II 3 G Ex ec IIC T6 Gc X for gas: Category 3G (zone 2)	VAEX2E	in conjunction with evaluation unit
CE <Ex> II 3 D Ex tc IIIC TX Dc X for dust: Category 3D (zone 22)	VAEX2E	in conjunction with evaluation unit
CE <Ex> II 2 G Ex ia IIC T6 Gb for gas: Category 2G (zone 1)	VAEX1	only in conjunction with: - isolation-/supply unit LDX2 <u>and</u> 'non-Ex evaluation unit' or - ATEX-conform, separate evaluation unit with Ex input - not valid for VAT-sensors temperature range of the medium as electrical apparatus for category 2G -40 ...+240°C

Compatible separate evaluation units

for non-Ex applications	UVA, μ P-Vortex, VT-VA, VP-VA, VTP-VA, flowtherm NT
for Ex applications	flowtherm Ex or isolation-/supply unit LDX2 in LDG16 housing in combination with evaluation units UVA, μ P-Vortex, VT-VA, VP-VA, VTP-VA in LDG housings (additional requirement: Ex input t, p)

Evaluation unit connection

for unit with 8-pin screw-type connector

plug 423-8	type of protection IP67	article no. A099/056
plug 680-8	type of protection IP40	A099/055

for unit with connecting terminals

stripped cable end	marked strands with end sleeves	A099/110
--------------------	---------------------------------	----------

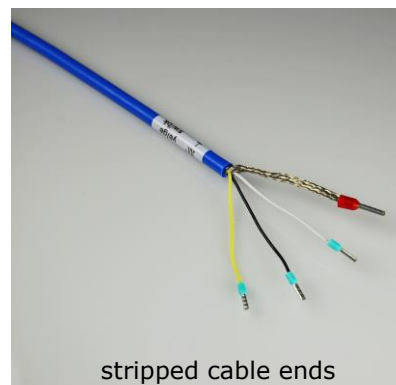

Extension rods

description	material	length	outside-diameter	article no.
SR42E-350	stainless steel, FKM-O-Ring	350 mm	42 mm	B099/510
SR42E-500	stainless steel, FKM-O-Ring	500 mm	42 mm	B099/511
SR42E-1000	stainless steel, FKM-O-Ring	1000 mm	42 mm	B099/512
SR42,4H-500	Hastelloy, FKM-O-Ring	500 mm	42.4 mm	B099/513
SR42,4H-1000	Hastelloy, FKM-O-Ring	1000 mm	42.4 mm	B099/514
SR42T-500	titanium, FKM-O-Ring	500 mm	42 mm	B099/515

Direction indicator / Calibration certificate

	description	article no.
	direction indicator RZ42	B099/957
	direction indicator RZ42.4	B099/958
	calibration certificate	KLB
	DAkKS / ISO 17025 calibration certificate	on request

Probe guide pieces *		
type	description	article no.
SFK 42 E-100 / F-DN50 PN16 drawing 3 , page 8	connection: flange DN50PN16 EN1092-1 max. pressure: 6 bar / 600 kPa temperature: -20 ... +240 °C materials: stainless steel, FKM fixation: clamp yoke length: 100 mm	B004/317
SFK 42 E-260 / F-DN50 PN16 drawing 3 , page 8	connection: flange DN50PN16 EN1092-1 max. pressure: 6 bar / 600 kPa temperature: -20 ... +240 °C materials: stainless steel, FKM fixation: clamp yoke length: 260 mm	B004/307
SFK 42 E-260 / F-DN80 PN16 drawing 3 , page 8	connection: flange DN80PN16 EN1092-1 max. pressure: 6 bar / 600 kPa temperature: -20 ... +240 °C materials: stainless steel, FKM fixation: clamp yoke length: 260 mm	B004/308
SFK 42 E-150 / G 2" drawing 2 , page 8	connection: outside thread G 2" max. pressure: 3 bar / 300 kPa temperature: -20 ... +240 °C materials: stainless steel, FKM fixation: clamp yoke length: 150 mm (probe guide piece)	B004/231
SFK 42 E-150 / G 2" with ball valve drawing 2 , page 8	connection: outside thread G 2" (SFK) inside thread G 2" (ball valve) max. pressure: 3 bar / 300 kPa temperature: -20 ... +240 °C materials: stainless steel, FKM fixation: clamp yoke length: 150 mm (probe guide piece) 134 mm (ball valve)	B004/230
SFK 42,4 E-260 / F-DN50 PN16 drawing 3 , page 8	connection: flange DN50PN16 EN1092-1 max. pressure: 6 bar / 600 kPa temperature: -20 ... +240 °C materials: stainless steel, FKM fixation: clamp yoke length: 260 mm	B004/310
SFK 42,4 E-260 / F-DN80 PN16 drawing 3 , page 8	connection: flange DN80PN16 EN1092-1 max. pressure: 6 bar / 600 kPa temperature: -20 ... +240 °C materials: stainless steel, FKM fixation: clamp yoke length: 260 mm	B004/311
SFZ 42 PVDF-225 / F-DN50 PN16 ** drawing 3 , page 8	connection: flange DN50PN16 EN1092-1 max. pressure: 3 bar / 300 kPa temperature: -20 ... +150 °C materials: PVDF, FKM fixation: collet length: 225 mm	B004/309
<p>* Probe guide pieces enable a process connection via threaded sleeve or flange connection. They are moveable and rotatable on the probe shaft. ** PVDF probe guide pieces are not suitable for ATEX applications.</p>		

Probe guide pieces* (cont'd)

type	description	article no.
SFZ 42,4 PVDF-225 / F-DN50 PN16** drawing 3, page 8	connection: flange DN50PN16 EN1092-1 max. pressure: 6 bar / 600 kPa temperature: -20 ... +120 °C materials: PVDF, FKM fixation: collet length: 225 mm	B004/312

* Probe guide pieces enable a process connection via threaded sleeve or flange connection. They are moveable and rotatable on the probe shaft.

** PVDF probe guide pieces are not suitable for ATEX applications. Other probe guide pieces on request.

**Probe guide piece
drawing 2
(w/o ball valve)**

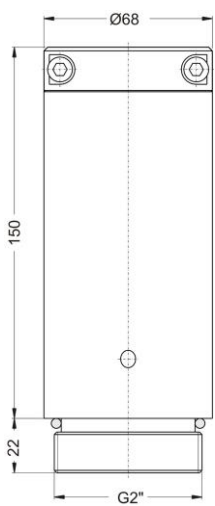

**Probe guide piece
drawing 3 - stainless steel**

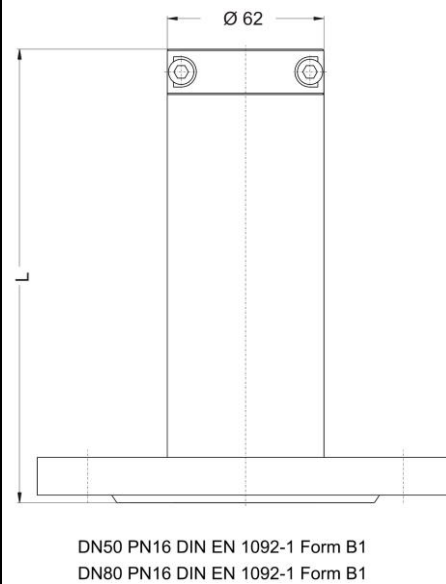

**Probe guide piece
drawing 3 - PVDF**

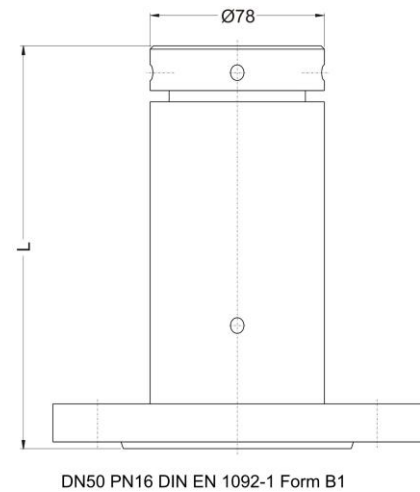

Sensor installation

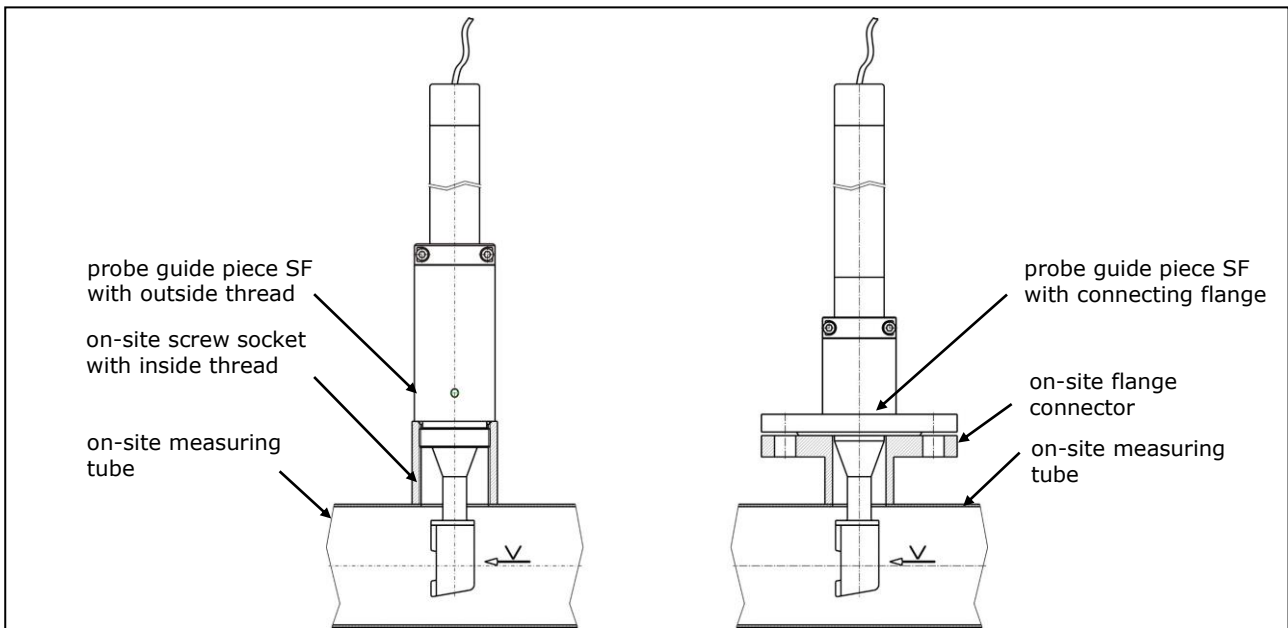

Wiring diagrams

VA40/42_100 °C sensors

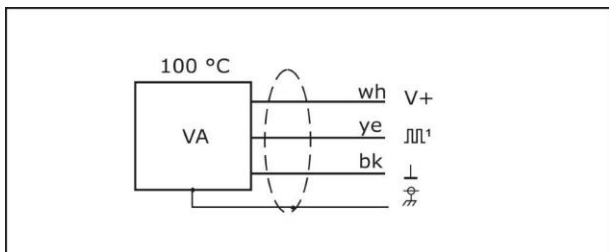

VA40/42_180 °C_240 °C sensors

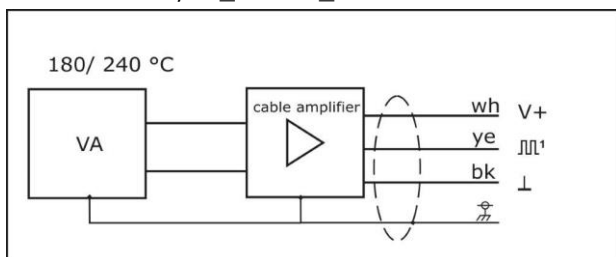

VAT40/42_100 °C sensors

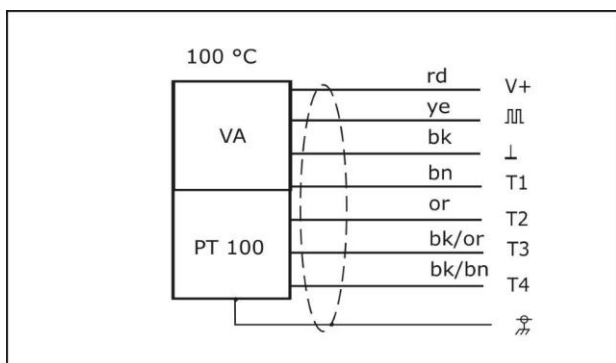

VAT40/42_180 °C_240 °C sensors

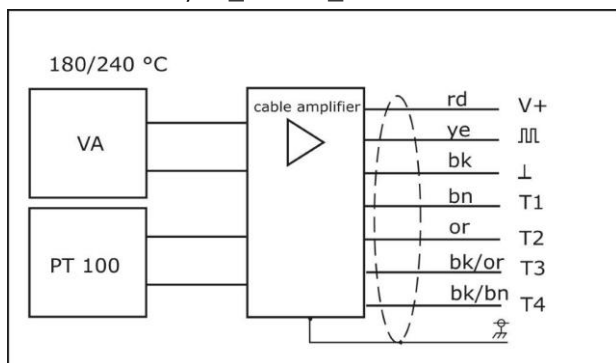



Vortex Flow Sensors VA

Probes · Probe Extensions · Probe Guides



Flow · Flow rate
Also combined with
temperature · Pressure

Specifications
Designs
Information for the user



The principle of measurement

derived from the Karman phenomenon of vortex shedding, is based on vortices being shed when a flowing medium reaches an obstruction or strut, whereby the vortex shedding frequency is a dimension for the flow velocity.



Vortex street

The flow vortices are ultrasonically scanned. In this way, compared to other scanning methods, the lower flow velocities can be measured and a greater turndown ratio can be obtained. The vortices modulate the ultrasonic beam between an ultrasonic transmitter and receiver. The vortex frequency results from the demodulation.

A great advantage of the vortex principle of measurement is well-founded - when measuring within the respective specifications - in the independence of density, pressure and temperature from the working medium.

Vortex measuring probes have no moving parts. Even in rough conditions they prove to have outstanding fatigue strength, excellent repeatability, long-term stability are overload-proof and interchangeable. Measuring is practically inertia-free. The length of cable between sensor and electronic evaluation unit can measure up to several hundred meters.

Types of sensor with vortex flow sensors

- v-sensors for measuring the flow velocity v: VA
- vt-sensors for measuring the flow velocity v and also the temperature t: VAT
- v-sensors for sensing the \pm direction of flow: VAR
- v-sensors VA in protective system Ex ia IIC T6, category 1/2G (zone 0/1), 1/2D (zone 20/21) and 2G (zone 1)
- v-sensors for sensing the \pm direction of flow: VAR in Ex protection category 3G (zone 2) and 3D (zone 22)



TÜV qualification tested
for continuous measurement of exhaust flow rate in the case of officially approved outgoing air plants, garbage incinerating plants and industrial furnaces according to TA-Luft, 13th and 17th BImSchV.

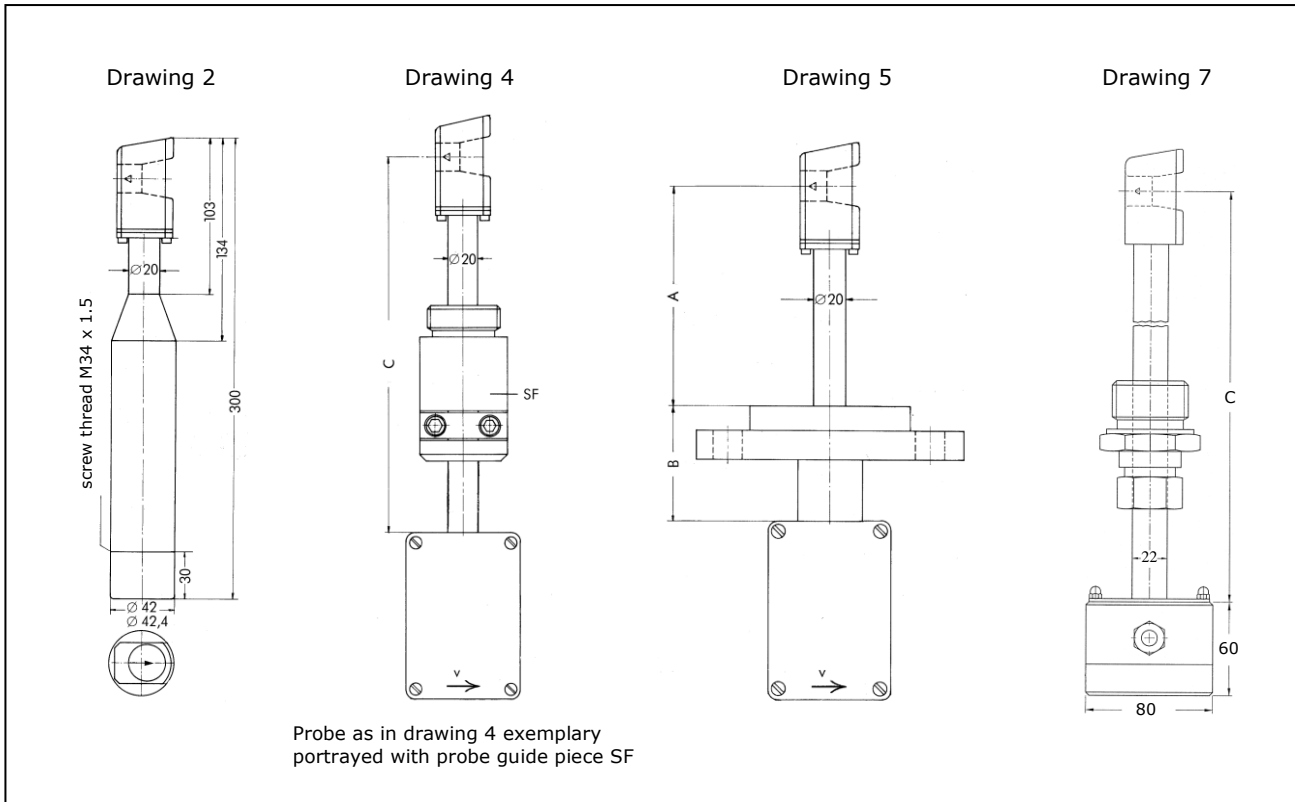

Designs

- extendable probes VA40/42 as in drawing 2 are determined for insertion into mediums with greater insertion depths, for instance greater than 1 m. When screwed together with extension tubes they can be moved to determine the best measuring position.
- probes VA40/20 of an exact length as in drawing 4 are for insertion in mediums with insertion depths of up to approx. 1.5 m. These can also be moved to determine the best measuring position.
- probes VA40/22 of an exact length as in drawing 7 are for insertion in mediums with insertion depths of up to 1 m. These can also be moved.
- probes VA40/20 of an exact length as in drawing 5 are for insertion in mediums with lesser to medium insertion depths. The measuring position is determined by the inside diameter of the pipe and the length of the single ended flanged nipple.
- vortex flow sensors VAR40, sensing +/-direction of flow are, for instance, suitable for measurement of flow in traffic and waste dump tunnels.

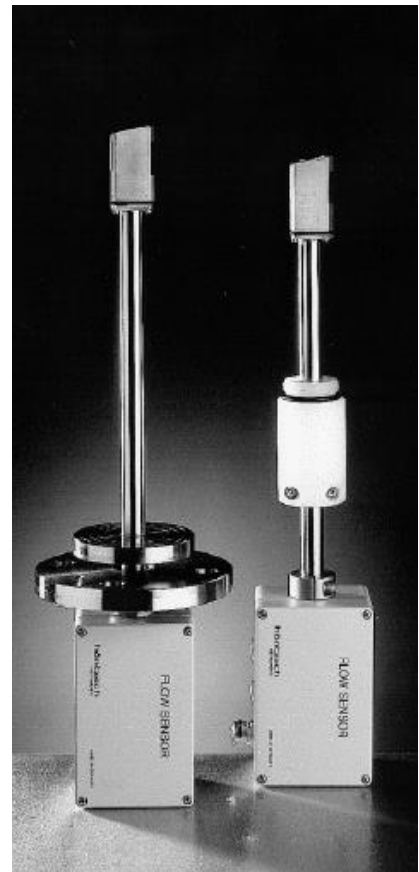
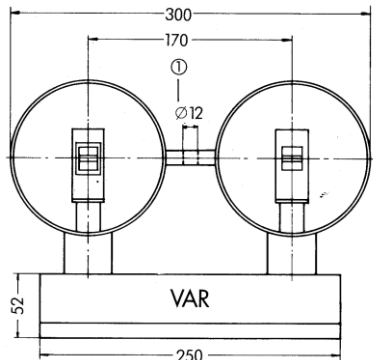



Model designations of the vortex probes VA 40

Types of sensor

VA vortex flow sensor, v-sensor

VA with 3 conductors

VAT vortex flow sensor with integrated temperature probe Pt100, vt-sensor: v-sensor VA with 3 conductors; t-sensor Pt100, DIN IEC 751, tolerance 1/3 class B, 4-wire configured

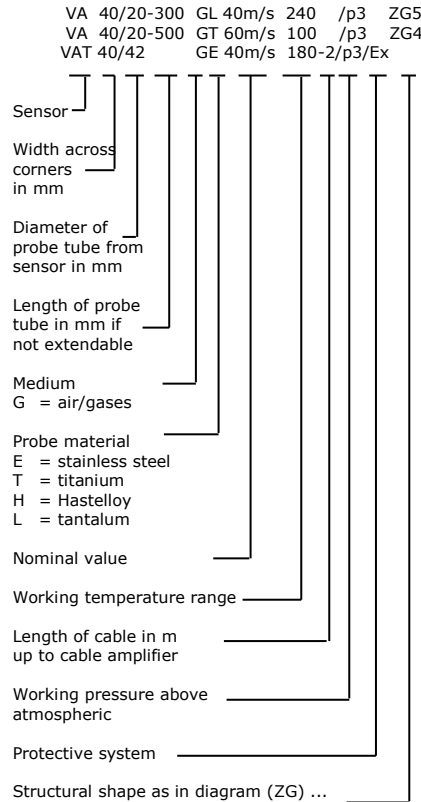
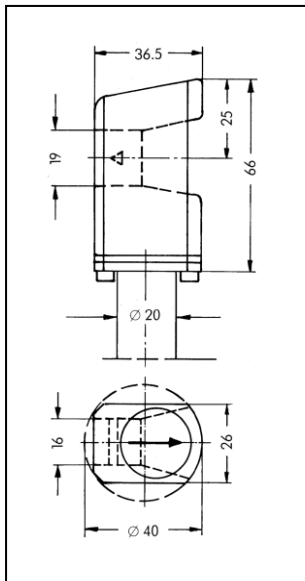

The choice of materials should be made with a view to the required corrosion resistance. Hastelloy B2 upon request. Instead of the standard seal material VITON®, KALREZ® or, for low temperatures, SILICONE, are also available on request.

Medium

G air/gases

Vortex flow sensors VA40 are primarily intended for measurements in single-phase flow gas: air, gas mixtures with air, oxygen or nitrogen as a predominant constituent, methane, natural gas, torch gas, ammonia, argon, carbon monoxide, steam ...

Permissible are non-dominant admixtures of chlorine, fluorine, helium, hydrogen ...

Not suitable however are gas mixtures consisting predominantly of chlorine, fluorine, helium, hydrogen ...

Impurities in gases in the form of solids are of no impairment as long as abrasion does not result.

In comparison to Höntzsch vane wheel flow sensors, vortex flow sensors can be used for measuring in gases with a considerably intensive solids content, without impairing the fatigue strength. The medium may even contain fibres.

Width across corners

VA40 probes have a rectangular shape with 40 mm width across corners favourable for flow. Therefore they have to have insertion openings with a hole diameter larger than 40 mm for insertion in pipe lines or ducts.

Probe tube diameter from sensor

The connecting tube for all VA40 vortex flow sensors has a diameter of 20 mm, beginning at the sensor housing. VA40/42 probes expand approx. 40 mm after the sensor housing and then have a diameter of 42 mm or 42.4 mm respectively. The advantage of the VA40/42 is that the sensor housing can be fed through the boring of a probe guide piece or globe cock with a diameter of 42 mm or rather 42.4 mm. VA40/42 probes have a connection thread onto which the probe tube can be screwed for extension purposes.

Sensor materials

E stainless steel	
Sensor housing	1.4581
connection tubes	ceramics
seals	1.4571
	VITON®
T titanium	
sensor housing	titanium
	3.7161
connection tubes	ceramics
seals	titanium
	VITON®
H Hastelloy	
sensor housing	Hastelloy C4
	2.4610, opt.
connection tubes	Hastelloy C22,
seals	ceramics
	Hastelloy
	VITON®
L tantalum	
sensor housing	tantalum
	ceramics
connection tubes	tantalum
seals	VITON®

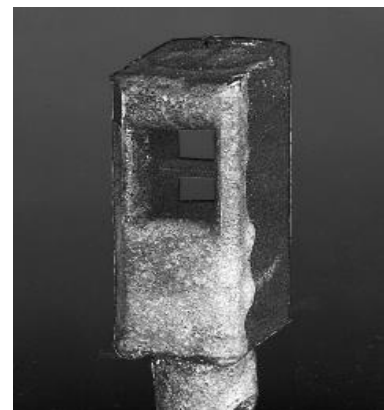

The pictured sensor with salt deposits was installed for several weeks in a bore hole for ventilation. The slight deposits on the strut can be easily seen. In soiled condition drifts of max. ±0.3 m/s result for velocities of up to approx. 12 m/s.



Likewise moisture in gases is of no disadvantage, as long as condensation does not set in. Should condensation arise it can influence measurement. The limits between 100 % saturated flow of gas, occasional condensation on the sensor, severe or slight condensation, are flowing. However, the possibility of measurement being influenced by condensation can be kept to a minimum when

- the sensor is positioned horizontally when occasional or slight condensation arises. This makes drainage easier at the strut and ultrasonic transmitter and receiver.
- the vortex signal processing module **VSM wet gases** is used when severe but not continually severe condensation arises. In the case of continual and severe condensation faulty measurements may still arise for the duration, even when using the VSM, especially when the velocity lies under approx. 4 m/s.

Measuring range

The smallest measurable value during velocity measuring v is dependent on diameter/width across corners d of the strut as well as the kinematic viscosity n of the gas and consequently on its density ρ or temperature. It is well-known from scientific research that shedding of vortices arises in a vortex street with Reynolds number $Re > 70...100$. From the relation

$$Re = \frac{v \cdot d}{\nu}$$

the smallest measurable value
 v (+20 °C) = 0.38 m/s
 v (+180 °C) = 0.81 m/s

for the Höntzsch strut with diameter/width across corners $d = 4$ mm e.g. with air under normal atmospheric conditions can be calculated with

$$v$$
 (+20 °C) = $15.13 \cdot 10^{-6} \text{ m}^2/\text{s}$
 v (+180 °C) = $32.43 \cdot 10^{-6} \text{ m}^2/\text{s}$

U155_VA_D_e_111216

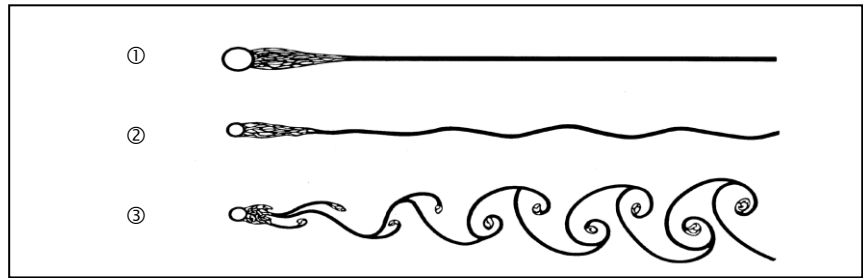

Vortex pattern downstream of a cylinder in a range of very low Reynolds' numbers according to Homann.

① $Re \approx 32$ ② $Re \approx 50$ ③ $Re \approx 70$

The kinematic viscosity n is defined as the ratio between dynamic viscosity η and density ρ
 $\nu = \eta / \rho$.

The greater the density of medium, for instance as a result of higher pressure, the lesser the kinematic viscosity, and the lesser the kinematic viscosity, this results from the aforementioned equation for the Reynolds' number, the lesser the smallest measurable value.

The frequency f of the shedding of vortices is determined by

$$f = \frac{S \cdot v}{d}$$

when $S =$ Strouhals' number. It can be seen from the relation of Strouhals' number Re , that the Strouhals' number is constant for large Reynolds' number range, the shedding frequency is consequently independent of temperature, density, pressure and viscosity.

Typical shedding frequency for the VA40 sensor with triangular strut:

$$1 \text{ m/s} = 63 \text{ Hz}$$

$$20 \text{ m/s} = 1450 \text{ Hz}$$

The nominal value can be adapted to the measuring function and designated to 20/25/30/35/40/60/80 m/s. Terminal value 25 m/s is necessary for application in installations according to TA-Luft, 13th and 17th BImSchV. Terminal value 80 m/s requires additionally the vortex signal processing module VSM.

<http://www.hoentzsch.com>

The velocity overload capacity of the vortex flow sensor VA40 is one of its outstanding features. It withstands up to 80 m/s. Because of the mechanically stable design of the probe even greater overload capacity can be expected. If the flow velocity is greater than the probe individual nominal value, then the measured value is, as a rule, lower than actual velocity value, seldom however lower than the specified nominal value.

Vortex flow sensors are determined, to a large extent, for measurement of uniform flow velocities. Flow conditions as in the case of pulsating flow or oscillating flow can influence measuring dependent from frequency (>5 Hz) and amplitude (>0.3 m/s). High endurance of the vortex flow sensors follows independent of flow conditions within the measurement range and independent of velocity overloading.

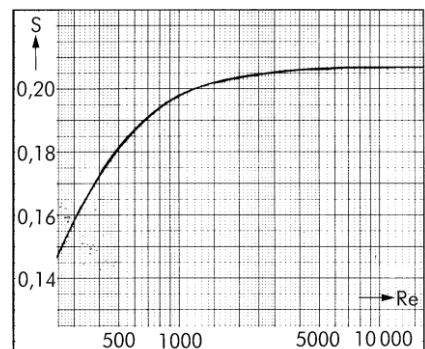



Working temperature range

100	-20 °C ...	+100 °C	C VITON
	-25 °C ...	+105 °C	S VITON
	0 °C ...	+100 °C	C KALREZ
	0 °C ...	+105 °C	S KALREZ
180	-20 °C ...	+180 °C	C VITON
	-25 °C ...	+205 °C	S VITON
	0 °C ...	+180 °C	C KALREZ
	0 °C ...	+205 °C	S KALREZ
240	-20 °C ...	+240 °C	C VITON
	-25 °C ...	+250 °C	S VITON

C = continuous operation

S = short-time operation

The respective sensor working temperature range is especially influenced by the materials of the ultrasonic transmitter and receiver, the cable, as well as the seals. Measurements at temperatures for which short-time operation is specified should only last for a few minutes. If this advice is adhered to, then the measuring probe cannot be damaged. In the case of vt-sensors the working temperature range corresponds to the temperature measurement range. Continuous working temperature range at temperatures higher than +100°C or rather lower than -25 °C is moreover achieved by the active electronic components in a so-called cable amplifier being positioned at a distance from areas with high/low temperatures. The cable amplifier can be found, in the case of VA40/42 probes, in a bush on the sensor connection cable or, with VA40/20 designs, in the connection housing. Permissible temperatures at the cable amplifier: -25... +100 °C. In order to keep to these regulations, in individual cases ambient temperature, the heat flow above the sensor connection cable or probe tube up to connection housing as well as eventual thermal radiation must be paid attention to. A cable length of 0.4 m is sufficient between the place at which a sensor connection cable comes out of a zone of for example +240 °C up to the bush with cable amplifier, when the cable amplifier is in surroundings with temperatures of no more than +40 °C.

Cable amplifier in a bush

Cable length up to cable amplifier
Standard length 2 m. For example, the sensor identification 180-2 or 180-10 means that the sensor is resistant up to +180 °C and the length of cable between sensor and bush with cable amplifier is either 2 m or 10 m.

Type of cable up to cable amplifier
PTFE-coated.

Cable after cable amplifier
Standard length 2 m. SILICONE-coated and temperature resistant up to +100 °C. Sensors for +100 °C also have as standard a 2 m long SILICONE-coated connection cable for max. +100 °C. When ordering please name the accompanying evaluation unit so that the appropriate connector plug /connection identification can be supplied.

Warning:

Do not sever or shorten the cable between probe and cable amplifier!

Cable amplifiers in a bush are moisture-proof but not impervious to aggressive gases.

Maximum working pressure

p3 sensor is tight and pressure resistant up to 3 bar/300 kPa

Protective system

Explosion protection

v-sensors are also available in compliance with **ATEX** in protective system **Ex ia IIC T6**, electric circuit intrinsically safe (category 1 and 2).

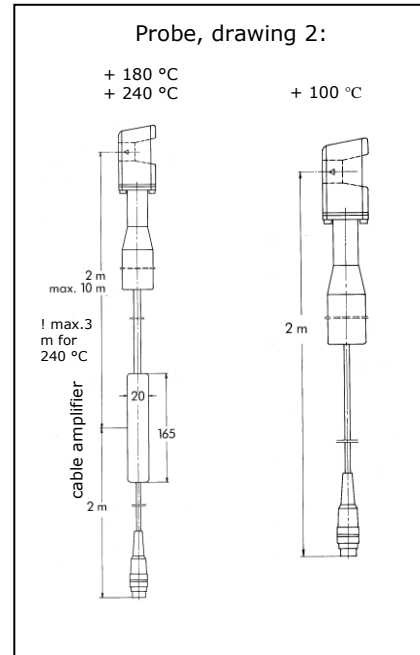

Protection against medium

Neither liquids nor corrosive gases must be allowed to penetrate the sensor from the cable connection side. In this respect please enquire about protected sensors, e.g. for use in aggressive gases, before ordering.

Seal materials

Standard material is VITON®. KALREZ® or SILICONE as an option to VITON®.

Working temperature range of the seal materials:

VITON® -20 °C... +240 °C **C**
-25 °C... +250 °C **S**

KALREZ® 0 °C... +300 °C **C**

PTFE/
TEFLON -40 °C... +260 °C **C**
-40 °C... +300 °C **S**

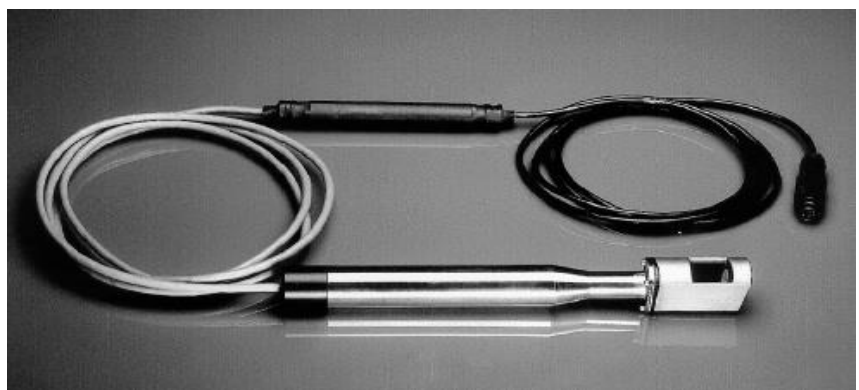



Probe extensions SR

are used for deeper insertion of probes in mediums, when the standard probe length is not sufficient for the required insertion depth.

Extendable probes VA40/42 or VA40/42.4 have, for this purpose, a connection thread onto which extension tubes can be fitted which are also suited for feed-through of sensor connection cable, if necessary bush with cable amplifier and connector plug. In addition they are protected against mediums - water or corrosive gases - which should not be allowed to penetrate the sensor from the cable connection side. Probe tubes are suitable for use with probe guide pieces, even in corrosive mediums or at high temperatures and offer a mechanically steady probe support.

Probe tubes made of titanium can be manufactured only together with a complete order with the same diameter. The diameter of these tubes may differ slightly from the respective nominal diameter. Probe guide pieces must be manufactured to match these probe tubes.

The mechanical burden of the tubes on the connection threads (burden due to weight of probe and extension tube as well as force of the flowing medium) limits the number of extension tubes which can be screwed together. Besides this, the sensor must not be allowed to undergo any vibration. For the most cases we recommend that not more than 4 extension tubes of 350 mm or 500 mm in length or rather 2 extension tubes of 1000 mm in length should be screwed together without additional support.

U155_VA_D_e_111216

Seal materials

As a rule VITON® O-rings are suitable on the screw fittings of extension tubes.

KALREZ® O-rings can only be recommended if the corrosion resistance of VITON should not be adequate. KALREZ® O-rings are temperature resistant for certain mediums, according to DuPont, in a range from 0 °C ... +300 °C.

KALREZ® O-rings available on request.

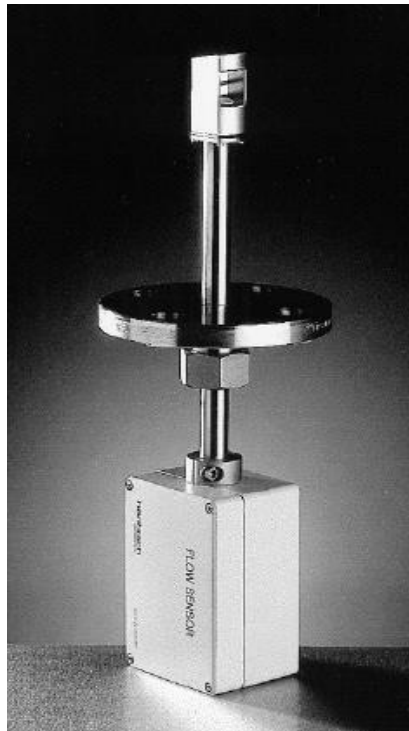

SFB with flange



SFZ with globe cock

Probe guide pieces SF

are used for inserting and retracting probes in and out of pipelines and ducts. The fixing device of the probe tube is to be chosen taking the temperature and pressure operating conditions into consideration.

SFB SF with clamping bush for unlimited repeated positioning of a probe at low subatmospheric and above atmospheric pressures

SFZ SF with collet chuck for unlimited repeated positioning of a probe at subatmospheric pressures/pressures above atmospheric of up to 10 bar

SFK SF with clamp strap for unlimited repeated positioning of a probe at subatmospheric pressures/pressures above atmospheric of up to 10 bar

<http://www.hoentzsch.com>



Profile factor PF

In larger free jet as well as in larger ducts and measuring tubes the local velocity v_p will be displayed with $PF = 1.000$. PF is also used to calculate the local velocity v_p to the average velocity v_m in a measurement cross section:

$$v_m = v_p \cdot PF$$

When measuring with vortex flow sensors VA40 in circular measurement cross-sections with interior diameter D_i

- centric positioning of the sensor
- irrotational flow
- developed flow profile
(measurement cross-section so chosen, that 20 D_i straight, unhindered input section amounts to 10 D_i straight, unhindered output section)

following coefficients are to be taken as a basis:

D_i	PF	D_i	PF
80	0,719	160	0,808
90	0,729	170	0,819
100	0,738	180	0,830
110	0,750	190	0,839
120	0,761	200	0,842
130	0,773	300	0,845
140	0,784	400	0,850
150	0,796	...	0,850

If these conditions for application of the coefficients are not prevailing then a pre-examination of flow should be carried out in the greater measurement cross section with $PF = 1.000$. As a result of this examination an optimal measurement point is to be determined and the corresponding coefficient is to be set.

For further information please consult VDI/VDE 2640, "Measurement of velocity area methods in flow cross-sections".

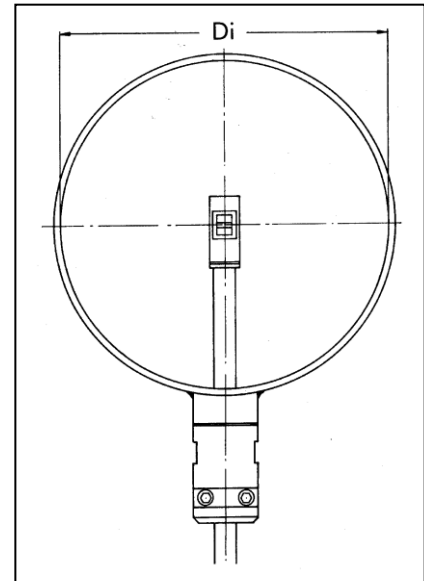

Design,
Manufacture, Sales

Flow · Flow rate also
combined with
temperature · Pressure

Höntzsch GmbH & Co. KG
Gottlieb-Daimler-Straße 37
D-71334 Waiblingen (Hegnach)
Telefon +49 7151 / 17 16-0
Telefax +49 7151 / 5 84 02
E-Mail info@hoentzsch.com
Internet www.hoentzsch.com

® : DuPont trademark

Subject to alteration