

AR652

Universal single-channel controller



Single-channel universal regulator with elements fuzzy logic PID



- control and monitoring of temperature and other physical values (humidity, pressure, level, speed, etc.) processed to a standard electrical signal (0/4÷20mA, 0÷10V, 0÷60mV, 0÷2,5kΩ)
- 1 universal input (thermometer, thermocouple and analogue)
- BIN programmable digital input for changing operational mode of the controller: control start/stop, manual/automatic mode for outputs, two-position switching of the set value (day/night), keyboard lock
- 2 or 3 outputs of ON/OFF type with the following characteristics:
 - output 1 (main): ON-OFF with hysteresis, PID, fuzzy logic (auto-tuning) PID
 - output 2, 3 (auxiliary/alarm): ON-OFF with hysteresis
- analogue output 0/4÷20mA or 0/2÷10V (constant-control, retransmission)
- advanced function of selecting PID parameters with fuzzy logic elements
- available for binary and analogue outputs, for setting the value of the output signal in the range of 0 ÷ 100%
- programmable operation characteristics (process controller, ramping)
- built-in 24 Vdc power supply for supplying on-site transducers
- two-line LED digital readout with adjustable brightness:
 - Upper display - measured value,
 - Bottom display - setpoint of output 1
- RS485 serial interface, galvanically isolated, MODBUS-RTU
- compensation of line resistance for resistance sensors
- temperature compensation of thermocouple cold ends
- programmable input, range of indications (for analogue inputs), options for adjustment, alarms, communication, access and other configuration parameters
- access to configuration parameters protected with a user password
- methods for configuring parameters:
 - via membrane keyboard (IP65) located on the front panel of the device
 - via RS485 or PRG AR955/GP programmer and freeware: ARsoft-LOG (Windows 7/8/10)
- software and programmer allow you to view the measured value and quickly configure single or few sets of parameters previously saved in the computer for re-use, e.g. in other controllers of the same type (duplicate configuration)
- ingress protection rating: IP65 from the front
- high accuracy, long-term stability and immunity to interference
- optional to choose (in the ordering method): power supply 24Vac/dc, output SSR, analog output 0/2÷10V, digital input BIN and interface RS485

Contents of set:

- regulator with handles mounting in the window
- user manual
- warranty card

Available accessories:

- programmer AR955/GP (with optional adapter)
- RS485 to USB converter

DIMENSIONS, INSTALLATION DATA

Enclosure dimensions	96x48x79 mm
Panel window	92x46 mm
Fixing methods	panel, grips on the side of the enclosure
Material	self-extinguishing polycarbonate NORYL 94V-0

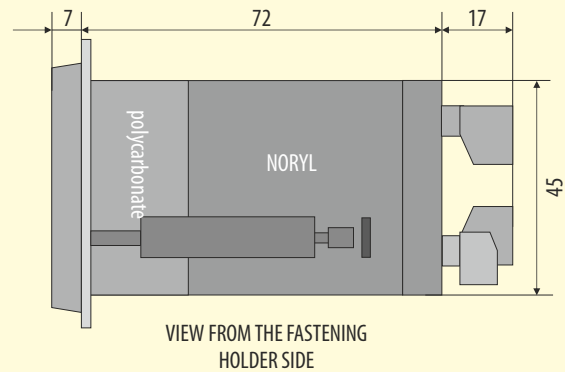

TERMINAL STRIPS, ELECTRICAL CONNECTIONS

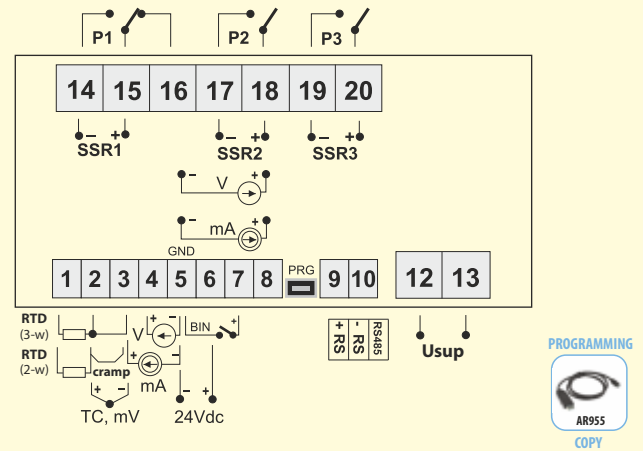

How to order

AR652 / □ / □ / □ / □ / □			
Supply	Code	Outputs 1, 2	Code
230 Vac	S1	relay	P
24 Vac/dc	S2	SSR	S
		Output 3	Code
		relay	P
		SSR	S
		Analog output	Code
		0/4÷20mA	WA
		0/2÷10 V	WU
		Interface RS*	Code
		interface RS485	RS485

* option for an extra fee

For example:

AR652 / S1 / S / P / RS485 / P

AR652, supply 230 Vac, main output (1) SSR, auxiliary output (2 i 3) relays, interface RS485

TECHNICAL DATA

Universal inputs (programmable)		measurement ranges
- Pt100 (RTD, 3- or 2-wire)		-200 ÷ 850 °C
- Ni100 (RTD, 3- or 2-wire)		-50 ÷ 170 °C
- Pt500 (RTD, 3- or 2-wire)		-200 ÷ 620 °C
- Pt1000 (RTD, 3- or 2-wire)		-200 ÷ 520 °C
- thermocouple J (TC, Fe-CuNi)		-40 ÷ 800 °C
- thermocouple K (TC, NiCr-NiAl)		-40 ÷ 1200 °C
- thermocouple S (TC, PtRh 10-Pt)		-40 ÷ 1600 °C
- thermocouple B (TC, PtRh30PtRh6)		300 ÷ 1800 °C
- thermocouple R (TC, PtRh13-Pt)		-40 ÷ 1600 °C
- thermocouple T (TC, Cu-CuNi)		-25 ÷ 350 °C
- thermocouple E (TC, NiCr-CuNi)		-25 ÷ 820 °C
- thermocouple N (TC, NiCrSi-NiSi)		-35 ÷ 1300 °C
- current ($R_{in} = 50 \Omega$)		0/4 ÷ 20 mA
- voltage ($R_{in} = 110 k\Omega$)		0 ÷ 10 V
- voltage ($R_{in} > 2 M\Omega$)		0 ÷ 60 mV
- resistance (3- or 2-wire)		0 ÷ 2500 Ω
Number of measurement inputs		1
Response time for measurements (10 ÷ 90%)		0,25 ÷ 3 s (programmable)
Resistance of leads (RTD, Ω)		$R_L < 25 \Omega$ (for each line)
Resistance current (RTD, Ω)		400 μ A (Pt100, Ni100), 200 μ A (remaning)
Processing errors (at 25°C ambient temperature):		
- basic	- for RTD, mA, V,mV, Ω	0,1 % of measuring range \pm 1 digit
	- for thermocouples	0,2 % of measuring range \pm 1 digit
- additional for thermocouples		<2 °C (cold ends temperature)
- additional caused by ambient temperature changes		< 0,003 % of input range /°C
Resolution of measured temperature		0,1 °C
Binary inputs (contact or voltage <24V)		bistable, active level: short-circuit or < 0,8 V
Communication interface (RS485 i PRG, do not use at the same time)	- RS485 (galvanically separated), option - PRG programming link (no separation), standard	- bitrate 2,4 ÷ 115,2 kb/s, - format 8N1 (8 data bit, 1 bit stop, no parity bit), - MODBUS-RTU protocol (SLAVE)
Outputs (3 relays or SSR)	- relay (P1, P2, P3), standard - SSR (SSR1, SSR2, SSR3), option	8A / 250Vac (for resistive loads), 1 main (SPDT), 2 additional (SPST-NO) transistor type NPN OC, 11V, internal resistance 440 Ω
Analogue outputs (1 current or voltage)	- current 0/4 ÷ 20 mA (standard) - voltage 0/2 ÷ 10 V (option) - output basic error	maximum resolution 1,4 μ A (14 bit) output load $R_o < 350 \Omega$ maximum resolution 0,7 mV (14 bit) output load $I_o < 3,7$ mA ($R_o > 2,7 k\Omega$) < 0,1 % of output range
7-segment LCD display with brightness control	- top - bottom	red 4 digits, height 14 mm green 4 digits, height 10 mm
Signalling	- relays active - messages and errors	LED's red LED dispaly
Power supply (Usup)	- 230Vac (standard) - 24Vac/dc (option)	85 ÷ 260 Vac/ 3VA 20 ÷ 50 Vac/ 3VA, 20 ÷ 72 Vdc/ 3W
Power supply to filed transmitters		24Vdc / 30mA
Rated operating conditions		0 ÷ 50°C, <100 %RH (non-condensing)
Working environment		air and neutral gases
Protection rating		IP65 front, IP20 of the connections side
Weight		~200g
Electromagnetic compatibility (EMC)		- immunity: acc. to PN-EN 61000-6-2 - emission: acc. to PN-EN 61000-6-4