

## TURBINE FLOW METER LWGY

**NEW**  
**2023 MODEL**



### Features

Liquid turbine flowmeter is a kind of speed instrument, which has the advantages of high accuracy, good repeatability, simple structure, small pressure loss and convenient maintenance. It is used to measure the volume flow of low viscosity liquid in closed pipe. In the petroleum, chemical, metallurgy, water supply, paper and other industries with a wide range of applications

### Technical Data

**Measuring principle :** Turbine flow meter  
**Maximum viscosity medium :** 15 cSt  
**Flow range :** See the table (page 2)  
**Flow unit :** m<sup>3</sup>/m, m<sup>3</sup>/h, l/m, l/h, Gal/m, Gal/h, Kg/m, Kg/h, t/m, t/h  
**Accuracy :** ±0.5% of reading, (Option : ±0.2% of reading)  
**Repeatability :** ±0.2 %  
**Pipe Diameter :** DN4...DN200  
**Process Connection :** Thread, Flange, Clamp  
**Pressure resistance :** 16 bar (standard)  
**Pressure resistance (option) :** 25, 40, 63 bar (for Thread)  
**Pressure resistance (option) :** 25, 40, 63 ....420 bar (for Flange)  
**Liquid Temperature :** -20...+80 °C (Option : -20...+150 °C)  
**Ambient Temperature :** -10...+65 °C  
**Ambient Pressure :** 86...106 kPa  
**Relative Humidity :** 5...90 %RH  
**Output :** Pulse, 4-20mA, RS-485, HART (Please see ordering code)  
**Power Supply :** 24 Vdc or 3.6V lithium battery  
**Housing Material :** 304 Stainless Steel (Option : 316 Stainless Steel)  
**Bearings and Shaft Material :** Tungsten Carbide  
**Retaining Rings Material :** 316 Stainless Steel  
**Rotor Material :** Stainless Steel  
**Protection class :** IP65  
**Approval :** Ex d II T6 Gb (Option)  
**Standard :** CE, EN61326-1

### Medium



Oil / Fuel



Water / RO water



Beer



Milk

*\*Note: Furthermore, these materials that are shown, please do not hesitate to contact us for consulting*

### Application



Water treatment



Petrochemical



Chemical Monitoring

### www.omi.co.th

**Omega Measuring Instrument Co., Ltd.**  
 Tel : 02-105-4676  
 Fax : 02-903-0080 ext. 6867  
 Email : info@omi.co.th  
 Line : @omith



Upstream Oil Transportation



Off-shore Exploration

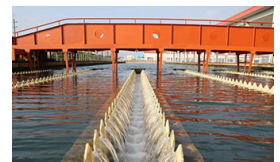

Water Supply

## TURBINE FLOW METER LWGY

### Flow rate and Pressure rating

Nominal Diameter		Standard Flow Range	Standard Pressure (all type)	**Customized Pressure (Thread)	**Customized Pressure (Flange)
mm	inch	m <sup>3</sup> /h	MPa	MPa	MPa
4	-	0.04-0.4	1.6	2.5, 4.0, 6.3	2.5, 4.0, ..., 42
6	-	0.06-0.6	1.6	2.5, 4.0, 6.3	2.5, 4.0, ..., 42
10	3/8	0.15-1.5	1.6	2.5, 4.0, 6.3	2.5, 4.0, ..., 42
15	1/2	0.4-8	1.6	2.5, 4.0, 6.3	2.5, 4.0, ..., 42
20	3/4	0.45-9	1.6	2.5, 4.0, 6.3	2.5, 4.0, ..., 42
25	1	0.5-10	1.6	2.5, 4.0, 6.3	2.5, 4.0, ..., 42
32	1-1/4	0.8-15	1.6	2.5, 4.0, 6.3	2.5, 4.0, ..., 42
40	1-1/2	1-30	1.6	2.5, 4.0, 6.3	2.5, 4.0, ..., 42
50	2	2-40	1.6	2.5, 4.0, 6.3	2.5, 4.0, ..., 42
65	2-1/2	4-70	1.6	2.5, 4.0, 6.3	2.5, 4.0, ..., 42
80	3	5-100	1.6	2.5, 4.0, 6.3	2.5, 4.0, ..., 42
100	4	10-200	1.6	2.5, 4.0, 6.3	2.5, 4.0, ..., 42
125	5	13-250	1.6	2.5, 4.0, 6.3	2.5, 4.0, ..., 42
150	6	15-300	1.6	2.5, 4.0, 6.3	2.5, 4.0, ..., 42
200	8	40-800	1.6	2.5, 4.0, 6.3	2.5, 4.0, ..., 42

\* The clamp connection can resist the maximum pressure 1.6 MPa (16 bar).

\*\*For customized pressure of thread and flange type. Please ask the sales department for special options.

### ● Special flange high pressure

Perform outstandingly in "High pressure" application

- Resist High= pressure up to **42 MPa** (420 bar)
- No need hole tapping on the body, so it is easy to make high pressure type

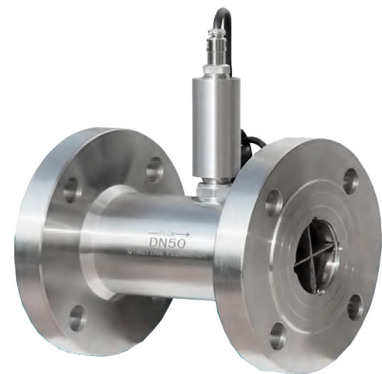

[www.omi.co.th](http://www.omi.co.th)

**Omega Measuring Instrument Co., Ltd.**

Tel : 02-105-4676

Fax : 02-903-0080 ext. 6867

Email : [info@omi.co.th](mailto:info@omi.co.th)

Line : @omith

## TURBINE FLOW METER LWGY

### Installation Dimensions

- Thread connection dimensions**

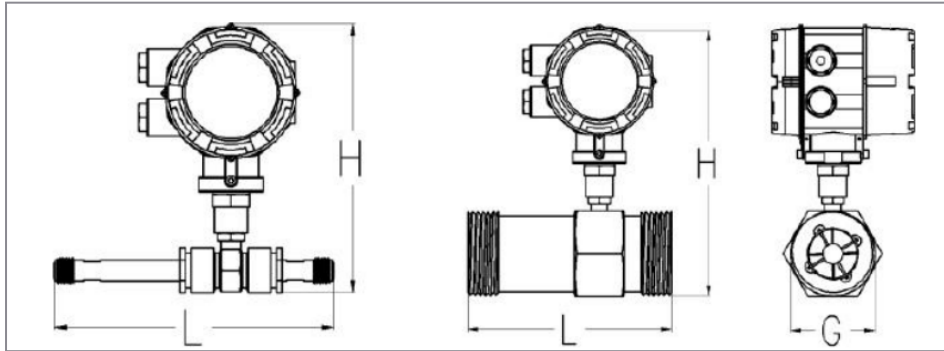

Diameter (mm)	L (mm)	H (mm)				G male Outside Thread	G male Inside Thread
		Pulse Type	Pulse Type with Ex.	4-20mA Type with Ex.	Intelligent Display Type		
4	225	140	145	145	210	G 1/2"	-
6	225	140	145	145	210	G 1/2"	-
10	345	145	150	145	210	G 1/2"	-
15	75	145	150	150	215	G 1"	G 1/2"
20	80	150	155	155	220	G 1"	G 3/4"
25	100	155	160	160	225	G 1 1/4"	G 1"
32	140	175	180	180	245	G 2"	G 1 1/4"
40	140	180	185	180	250	G 2"	G 1 1/2"
50	150	185	190	190	255	G 2 1/2"	G 2"



**Outside thread (Standard)**

for DN4-DN10  
extended straight pipeline



**Outside thread (Standard)**

for DN15-DN100  
Male thread



**Inside Thread (option)**

for DN15-DN50  
Female Thread

[www.omi.co.th](http://www.omi.co.th)

**Omega Measuring Instrument Co., Ltd.**

Tel : 02-105-4676

Fax : 02-903-0080 ext. 6867

Email : info@omi.co.th

Line : @omith

## TURBINE FLOW METER LWGY

### Installation Dimensions

- Clamp connection dimensions

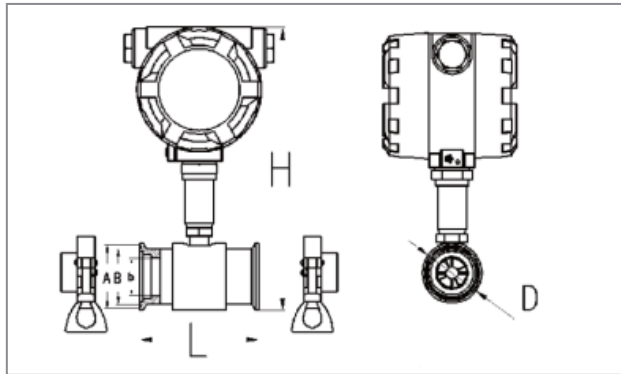

Diameter (mm)	L (mm)	D (mm)	A (mm)	B (mm)	b (mm)	H (mm)			
						Pulse Type	Pulse Type with Ex.	4-20mA Type with Ex.	Intelligent Display Type
4	50	50.5	46	40.5	4	145	150	150	210
6					145	150	150	210	
10					145	150	150	210	
15	100				15	155	160	160	225
20					160	160	160	225	
25					160	165	165	230	
32	120	32	165	165	165	230			
40	140	64	59	110	40	175	180	180	245
50	150	78	73.5	125	50	185	190	190	255
65	170	91	86	145	65	205	205	205	270
80	200	106	100.5	160	80	215	220	220	285
100	220	119	113	180	100	235	240	240	305



Example for using with clamp



*\*Note : product does not include clamp*

[www.omi.co.th](http://www.omi.co.th)

**Omega Measuring Instrument Co., Ltd.**

Tel : 02-105-4676

Fax : 02-903-0080 ext. 6867

Email : [info@omi.co.th](mailto:info@omi.co.th)

Line : @omith

## TURBINE FLOW METER LWGY

### Installation Dimensions

- Flange connection dimensions

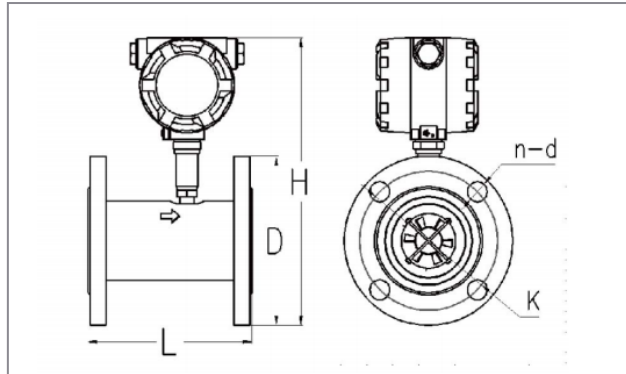

\*DIN flange PN16

Diameter (mm)	L (mm)	D (mm)	K (mm)	H (mm)				d (mm)	n
				Pulse Type	Pulse Type with Ex.	4-20mA Type with Ex.	Intelligent Display Type		
15	75	95	65	175	180	180	245	14	4
20	80	105	75	185	190	190	255	14	4
25	100	115	85	200	195	195	260	14	4
32	140	140	100	210	215	215	275	18	4
40	140	150	110	195	220	220	285	18	4
50	150	165	125	230	235	235	295	18	4
65	170	185	145	225	260	260	325	18	4
80	200	200	160	260	265	265	330	18	8
100	220	220	180	285	285	285	350	18	8
125	250	250	210	310	315	315	380	18	8
150	300	285	240	345	345	345	410	22	8
200	360	340	295	395	400	400	465	22	12



*\*Note : product has many type of flange. please see on ordering table.*

[www.omi.co.th](http://www.omi.co.th)

**Omega Measuring Instrument Co., Ltd.**

Tel : 02-105-4676

Fax : 02-903-0080 ext. 6867

Email : [info@omi.co.th](mailto:info@omi.co.th)

Line : @omith

## TURBINE FLOW METER LWGY

### Information

- Accuracy**

The turbine flow meter has high accuracy, please see at a graph. it shows when measure within own range that will be  $\pm 0.5\%$  of reading of accuracy. It is a bit of error. From a graph, it shows when measure out of range that will be  $\pm 5\%$  of reading of accuracy.

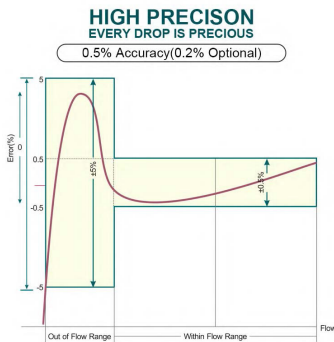

- Display**

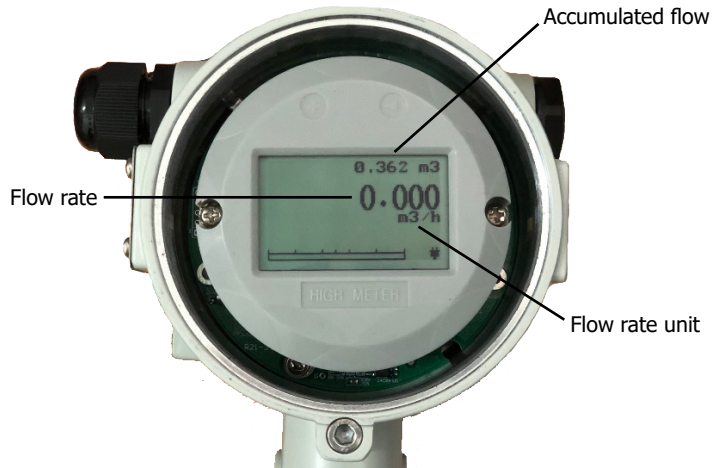

At display, there is flow rate unit. It is very convenient to watch through display. Furthermore, the flow meter can accumulate a flow rate and show above the flow rate value

### Installation

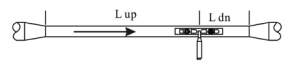
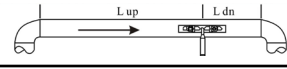
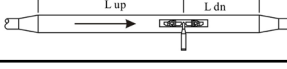
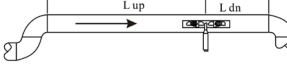
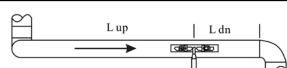
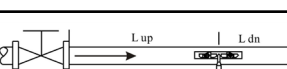
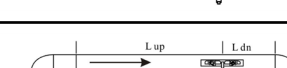
Type of pipe characteristic and the sensor location	Upstream	Downstream
	Distance <b>before</b> the center of the sensor ( <b>L up</b> )	Distance <b>After</b> the center of the sensor ( <b>L dn</b> )
	10 x diameter	5 x diameter
	15 x diameter	5 x diameter
	15 x diameter	5 x diameter
	15 x diameter	5 x diameter
	20 x diameter	5 x diameter
	30 x diameter	5 x diameter
	30 x diameter	5 x diameter

[www.omi.co.th](http://www.omi.co.th)

**Omega Measuring Instrument Co., Ltd.**

Tel : 02-105-4676

Fax : 02-903-0080 ext. 6867

Email : [info@omi.co.th](mailto:info@omi.co.th)









Line : @omith



## TURBINE FLOW METER LWGY

### Type of flow meter

● **Standard version**

Type	Thread type	Flange type	Clamp type
<b>NP/NA</b>			
<b>DB/DA/DH</b>			
<b>DR</b>			

*\*Please note : Every model can modify to high temperature version. The user can choose on ordering table.*

● **High temperature version**

For high temperature condition. The flow meter must have a special equipment to stand a high temperature.

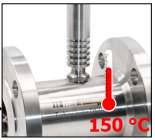

**H :** This is a cooling fin for heat exchange. Every model can be high temperature version

[www.omi.co.th](http://www.omi.co.th)

**Omega Measuring Instrument Co., Ltd.**  
 Tel : 02-105-4676  
 Fax : 02-903-0080 ext. 6867  
 Email : info@omi.co.th  
 Line : @omith

## TURBINE FLOW METER LWGY

### Ordering Code

**Example Order : LWGY-A-B-C-D-E-F-G**

**A : Pipe Diameter**

xx : DN4...DN200

**B : Display and Output Feature**

**NP** : No Display + pulse

**NA** : No Display + 4-20 mA

**DB** : Display + Battery

**DA** : Display + 4-20mA + pulse + RS485

**DR** : Remote Display (10 m cable) + 4-20mA + pulse + RS485

**DH** : Display + 4-20mA + pulse + HART

**C : Process Connection \*\***

**T** : Thread installation (standard : outside thread, 16 bar)

**F** : Flange installation (standard : DIN flange PN16)

**C** : Clamp installation

**D : Body Material**

**S04** : Stainless Steel 304

**S16** : Stainless Steel 316

**E : Fluid Temperature**

- : -20...+80 °C (standard)

**H** : -20...+150 °C

**F : Accuracy (option)**

- : 0.5% (standard)

**A** : 0.2%

**G : Explosion Proof (option)**

- : Non-Explosion proof

**EX** : Ex d II T6 Gb

### \*\*Special Process Connection

**TE25** : outside thread, 25 bar | **TE40** : outside thread, 40 bar | **TE63** : outside thread, 63 bar

**TI16** : inside thread, 16 bar | **TI25** : inside thread, 25 bar | **TI40** : inside thread, 40 bar | **TI63** : inside thread, 63 bar

**FD25** : Flange DIN PN25 | **FD40** : Flange DIN PN40

**FA150** : Flange ANSI 150 | **FA300** : Flange ANSI 300 | **FA600** : Flange ANSI 600

**FJ10** : Flange JIS 10K | **FJ20** : Flange JIS 20K | **FJ30** : Flange JIS 30K

### Example Ordering : LWGY-50-DA-F-S04-H-EX

Description : Turbine flow meter pipe diameter DN50, have monitor and output signal is 4-20 mA + pulse + RS485, Flange DIN PN16 connection, Body Material is Stainless Steel 304, resistance liquid temperature -20...+150°C, with explosion proof Ex d II T6 Gb.

[www.omi.co.th](http://www.omi.co.th)

**Omega Measuring Instrument Co., Ltd.**

Tel : 02-105-4676

Fax : 02-903-0080 ext. 6867

Email : info@omi.co.th

Line : @omith