

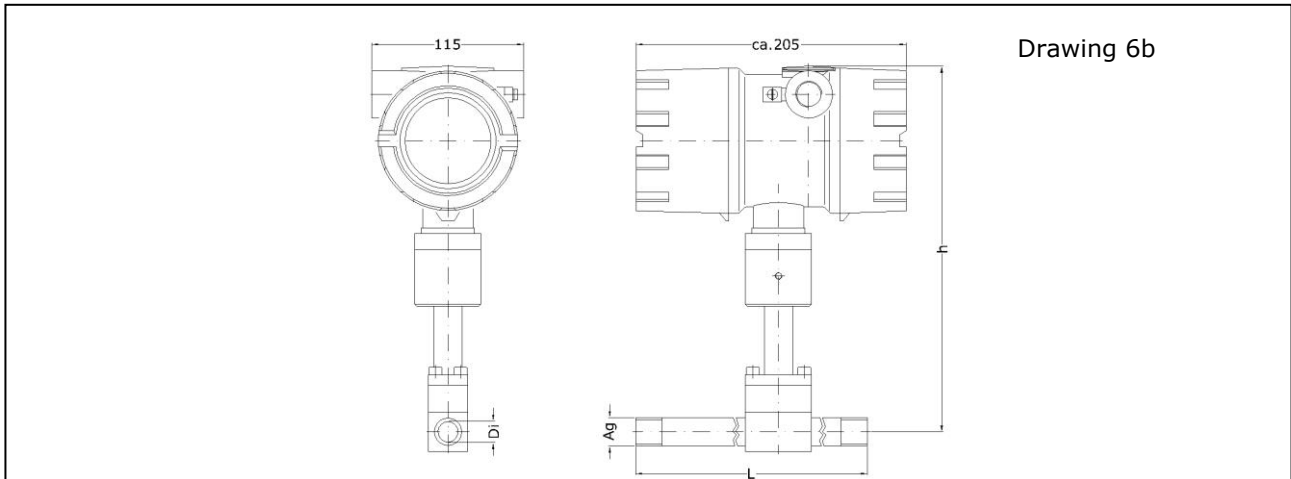

**Thermal flow sensor TA Di Ex-d with integrated, configurable transducer UTA in a flameproof enclosure for applications in explosive atmospheres**



Sensor TA Di Ex-d

**Measured variables**

- standard flow rate [m<sup>3</sup>/h, l/min], mass flow rate [kg/h], standard velocity [m/s]
- standard basis adjustable, default:  
temperature  $t_n = +21\text{ °C}$   
pressure  $p_n = 1014\text{ hPa}$

**Functional principle**

- flow measurement according to the heat transfer method
- temperature-compensated

**Design**

- measuring tube with integrated transducer and flameproof enclosure
- thin film sensor element

**Media**

- pure gases, gas mixtures: air, nitrogen, methane, natural gas, hydrogen, argon, carbon dioxide, helium, sulphur hexafluoride, propane, landfill gas, ...
- calibration can be carried out with a multitude of gases or gas mixtures to achieve the best measuring uncertainty

**Advantages**

- applications in explosive atmospheres:  
Ca0tegrory 1/2 G (Zone 0/1) and Category 1/2 D (Zone 20/21)
- high turndown (up to 1 : 1000)
- measuring range from 0.2 m/s
- low measurement uncertainty, even at lowest flow rates
- mass flow of air/gases without additional pressure and temperature detection
- no moving parts
- stainless steel sensor housing
- wider temperature and pressure resistance ranges
- low installation costs
- marginal pressure loss
- high durability
- sterilisable (material-resistance of sensor allowing)
- easy adjustment of parameters with HART<sup>®</sup> interface

**Examples of application**

- measuring
  - in explosive atmospheres
  - air flow rate
  - compressed air and gas consumption as well as leakage flow
  - in exhaust air
  - landfill gas
  - natural gas
  - in process gases
  - in burner control units
  - in air in low vacuum range with pressures higher than 200 hPa abs

**Particles, humidity and condensation**

- dust or fibre particles in the gas do not affect the measurement, as long as these are not abrasive or accumulate on the sensor
- deviations in values as a result of variable air humidity under normal atmospheric conditions are covered by the measuring uncertainty specifications



**Model designation / order code (example)**

<b>TA Di</b>	<b>16</b>	<b>G</b>	<b>E</b>	<b>60 m/s</b>	<b>140</b>	<b>p16</b>	<b>ZG6b</b>	<b>Ex-d</b>
(1)	(2)	(3)	(4)	(5)	(6)	(7)	(8)	(9)

**Basic types**

	<b>Article No.</b>
TA Di 16 GE 60 m/s / 140 / p16 ZG6b Ex-d	B017/001
TA Di 16 GE 120 m/s / 140 / p16 ZG6b Ex-d	B017/001-120M/S
TA Di 16 GE 150 m/s / 140 / p16 ZG6b Ex-d	B017/001-150M/S
TA Di 21.6 GE 60 m/s / 140 / p16 ZG6b Ex-d	B017/002
TA Di 21.6 GE 120 m/s / 140 / p16 ZG6b Ex-d	B017/002-120M/S
TA Di 21.6 GE 150 m/s / 140 / p16 ZG6b Ex-d	B017/002-150M/S
TA Di 27.2 GE 60 m/s / 140 / p16 ZG6b Ex-d	B017/003
TA Di 27.2 GE 120 m/s / 140 / p16 ZG6b Ex-d	B017/003-120M/S
TA Di 27.2 GE 150 m/s / 140 / p16 ZG6b Ex-d	B017/003-150M/S
TA Di 35.9 GE 60 m/s / 140 / p16 ZG6b Ex-d	B017/004
TA Di 35.9 GE 120 m/s / 140 / p16 ZG6b Ex-d	B017/004-120M/S
TA Di 35.9 GE 150 m/s / 140 / p16 ZG6b Ex-d	B017/004-150M/S
TA Di 41.8 GE 60 m/s / 140 / p16 ZG6b Ex-d	B017/005
TA Di 41.8 GE 120 m/s / 140 / p16 ZG6b Ex-d	B017/005-120M/S
TA Di 41.8 GE 150 m/s / 140 / p16 ZG6b Ex-d	B017/005-150M/S
<b>Other measuring tube diameters on request</b>	



**(1) Sensor type**

Thermal flow sensor TA Di Ex-d as measuring tube with flameproof enclosure

**(2) Dimensions**

Measuring tube inside-Ø Di [mm]	installation length l [mm]	installation height h [mm]	tube connection on both sides
16.0	480	282	Ag R 1/2" ** Gg RP 1/2"
21.6	650	287	Ag R 3/4" ** Gg RP 3/4"
27.2	820	287	Ag R 1" ** Gg RP 1"
35.9	1080	286	Ag R 1 1/4" ** Gg RP 1 1/4"
41.8	1250	289	Ag R 1 1/2" ** Gg RP 1 1/2"

\*\* Ag : tapered Whitworth external thread DIN 2999  
Gg : mating thread

**Input/output sections**

no additional input/output section on site necessary;  
length of input section 2/3 of installation length l, length of output section 1/3 of l

**(3) Media**

air, clean gases, gas mixtures with consistent mix ratio

**(4) Materials in contact with the medium**

stainless steel, glass, epoxy resin, VITON®



## (5) Measuring ranges\* air/nitrogen

	m <sup>3</sup> /h	kg/h	litre/min	m/s	1 m <sup>3</sup> /h equates to [m/s]
<b>TA Di 16 ...</b>					
... 60 m/s ...	0.15 ... 43	0.18 ... 52	2.4 ... 729	0.2 ... 60	1.38
... 120 m/s ...	0.15 ... 86	0.18 ... 104	2.4 ... 1448	0.2 ... 120	1.38
... 150 m/s ...	0.15 ... 109	0.18 ... 130	2.4 ... 1810	0.2 ... 150	1.38
<b>TA Di 21.6 ...</b>					
... 60 m/s ...	0.27 ... 79	0.32 ... 95	4.4 ... 1319	0.2 ... 60	0.758
... 120 m/s ...	0.27 ... 158	0.32 ... 190	4.4 ... 2638	0.2 ... 120	0.758
... 150 m/s ...	0.27 ... 198	0.32 ... 238	4.4 ... 3298	0.2 ... 150	0.758
<b>TA Di 27.2 ...</b>					
... 60 m/s ...	0.42 ... 125	0.50 ... 151	7.0 ... 2092	0.2 ... 60	0.478
... 120 m/s ...	0.42 ... 250	0.50 ... 300	7.0 ... 4184	0.2 ... 120	0.478
... 150 m/s ...	0.42 ... 314	0.50 ... 377	7.0 ... 5230	0.2 ... 150	0.478
<b>TA Di 35.9 ...</b>					
... 60 m/s ...	0.73 ... 219	0.88 ... 263	12.1 ... 3644	0.2 ... 60	0.274
... 120 m/s ...	0.73 ... 438	0.88 ... 526	12.1 ... 7288	0.2 ... 120	0.274
... 150 m/s ...	0.73 ... 547	0.88 ... 657	12.1 ... 9110	0.2 ... 150	0.274
<b>TA Di 41.8 ...</b>					
... 60 m/s ...	1.0 ... 296	1.2 ... 356	16.5 ... 4949	0.2 ... 60	0.202
... 120 m/s ...	1.0 ... 592	1.2 ... 712	16.5 ... 9880	0.2 ... 120	0.202
... 150 m/s ...	1.0 ... 741	1.2 ... 890	16.5 ... 12350	0.2 ... 150	0.202

\* all standard flow and standard velocity details pertaining to normal pressure  $p_N = 1014 \text{ hPa}$  and normal temperature  $t_p = +21 \text{ °C}$  (294.15 K)

## Measurement uncertainty / time constant

measurement uncertainty for flow rates NV/t with 1014 hPa and +21 °C  
 less than/equal to 40 m/s : 2 % of measured value + 0.02 m/s  
 greater than 40 m/s : 2.5 % of measured value  
 time constant : in seconds

## Storing a characteristic for application in other gases

based on	Article No.
calibration in air and conversion of the air characteristic for another gas, up to '60 m/s'	TA_TRANSFO (on request)
real gas calibration for achieving best measurement uncertainty	(on request)



### (6) Permissible temperature

medium	-10 ... +140 °C
ambient	-20 ... +50 °C

### Permissible ambient and media temperature ranges subject to the chosen temperature class. Ambient temperature (electronics) $T_U$ , media temperature $T_M$

Category 1/2G equipment		
Temperature class	$T_M$	$T_U$
T4	- 10 °C ... +60 °C	- 20 °C ... +50 °C
T3	- 10 °C ... +60 °C	- 20 °C ... +50 °C
Category 2G equipment		
Temperature class	$T_M$	$T_U$
T4	- 10 °C ... +130 °C	- 20 °C ... +50 °C
T3	- 10 °C ... +140 °C	- 20 °C ... +50 °C
T2	- 10 °C ... +140 °C	- 20 °C ... +50 °C
T1	- 10 °C ... +140 °C	- 20 °C ... +50 °C
Category 1/2D or 2D equipment		
maximum surface temperature		$T_U$
T 135 °C		- 20 °C ... +50 °C

### (7) Working pressure

max. 16 bar / 1.6 MPa overpressure
higher than 16 bar / 1.6 MPa on request

### (8) Design

as in Drawing 6b, Page 1
--------------------------

### (9) ATEX protection

for gas	: Ⓜ II 1/2 G Ex ia/d e [ia] IIC T4 Ga/Gb
for dust	: Ⓜ II 1/2 D Ex ia/tb IIIC T135°C Da/Db
sensor	: Category 1 (Zone 0 or 20)
transducer housing	: Category 2 (Zone 1 or 21)

### Installation position

any positioning under atmospheric pressure, with overpressure inflow must not come from above
---



**Ex-d transducer housing**

Dimensions	outside diameter/length/height: approx. 110/205/182 mm
material	aluminium cast alloy max. 0.5 % Mg, coated
Protection	IP68, IEC 529 and EN 60 529
Connection	glands for shielded cables with outside diameter 5 ... 9 mm, contacting of overall screen on the ground terminal in the housing
Alignment	rotatable by approx. 350 ° and lockable
Setup	dual chamber system consisting of: 1) electronics in Ex-d protection (flameproof enclosure) 2) connections in Ex-e protection (increased safety) with terminal block and cable glands

**Electromagnetic Compatibility (EMC)**

according to EN 61 000-6-2 / IEC77

**Transducer UTA integrated in the connection housing**

Analog output flow	4 ... 20 mA resistance max. 500 Ohm
Output limit value or quantity pulse	potential-free relay contact (normally-open), max. 300 mA / 27 VDC
Communication port	HART®, via modem adapter for PC connection and PC software UCOM (see under Accessories) output signals are electrically isolated from the power supply
Self-monitoring	parameter settings, sensor interface; in the case of error: analog output < 3.6 mA
Power supply	24 V DC (20 ... 27 V DC)
Power consumption	less than 5 W
Setting parameters	analog output, time constant, profile factor, tube inside diameter, limit value or quantity pulse (rating adjustable), 'working pressure' to zero correction (only relevant for $N_v < 1$ m/s), standard basis, standard density



Ex-d transducer housing with optional LCD display



**Accessories (optional)**

	Description	Article No.
LCD display	1 <sup>st</sup> row: 'instantaneous value': flow rate or flow velocity 2 <sup>nd</sup> row: 'counter' or 'error code' 2 x 16-digit, character height 5.5 mm, working temperature range -20 ... +50 °C display rotatable in 90 °-stages on removing the Ex-d housing window cover	A010/520
calibration certificate v/TA		KLB
HART® modem adapter	for changing setting parameters, for PC-USB connection	A010/101
PC software UCOM	for configuring the UTA via RS232	A010/052

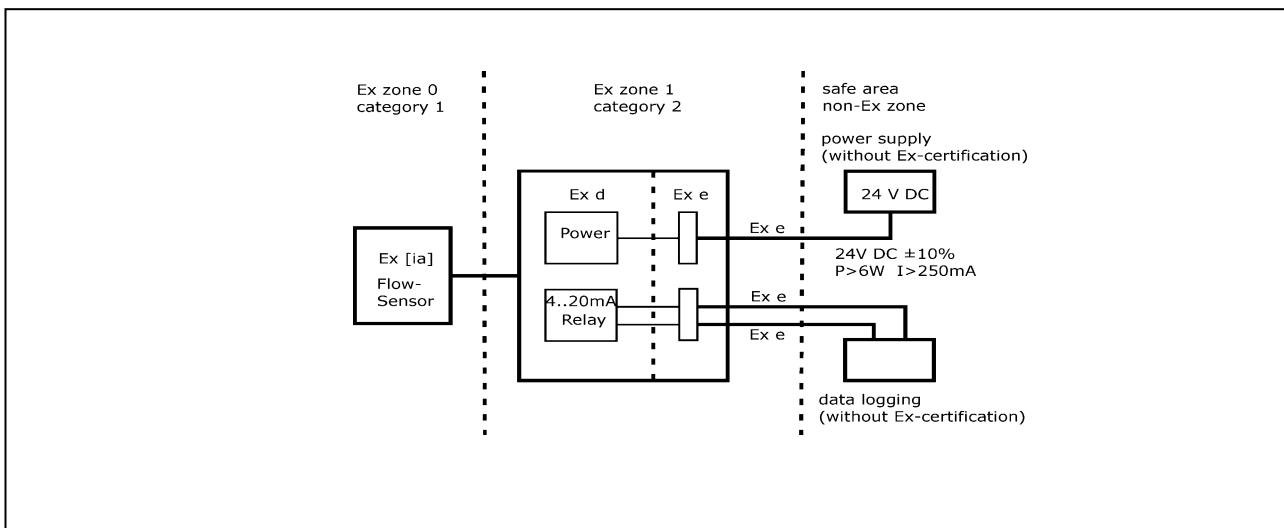

Diagram of Ex-Zones

® registered trademark:  
Dupont: VITON  
HART: HART Communication  
Foundation

**Höntzsch GmbH**

Gottlieb-Daimler-Straße 37  
D-71334 Waiblingen (Hegnau)  
Telefon +49 7151 / 17 16-0  
Telefax +49 7151 / 5 84 02  
E-Mail info@hoentzsch.com

**จัดจำหน่ายโดย**

**บริษัท โอเมก้า เมชเชอริง อินสทรูमेंท์ จำกัด**  
50/23 หมู่ 3 ต.มหาสวัสดิ์ อ.บางกรวย จ.นนทบุรี 11130  
Tel : 02 105 4676  
Fax : 02 903 0080 ext. 6867  
Email : info@omi.co.th