

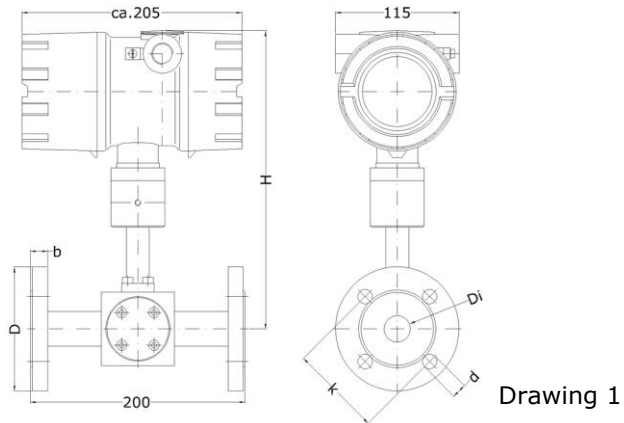

Vortex flow sensor VA Di Ex-d with integrated, configurable transducer UVA in a flameproof enclosure for applications in explosive atmospheres



VA Di ... ZG1 Ex-d

Measured variables

- actual flow rate
- actual velocity
- standard volume flow (in combination with pressure and temperature sensors)

Design

- measuring tube with flanged connection



Kármán vortex street

Functional principle

- vortex meter for measuring flow rate and volume
- ultrasonic acquisition of the frequency of the vortex shedding

Advantages

- compact unit for explosive atmospheres with local display
- applications in Category 1 (Zone 0 and 20); transducer housing approved for Category 2 (Zone 1 and 21)
- no external isolation/supply unit necessary
- recognizes even the lowest rates of flow, thanks to patented ultrasonic sensing
- high turndown (up to 1 : 100)
- no moving parts
- easy to clean
- high durability
- corrosion-resistant
- largely unaffected by gas composition
- marginal pressure loss
- easy adjustment of parameters with HART® interface

Examples of application

- flow measurement in explosive atmospheres: air, exhaust air, sludge activation air, engine intake air, natural gas, waste gas, process gas, biogas, car exhaust emissions, flare gas, water vapour, ...

Media

- primarily single-phase gas mixtures with air, nitrogen, oxygen, methane, natural gas, flare gas, ammonia, argon, carbon monoxide, water vapour, ... as dominant components; combustion gas, biogas, fermentation gas, sewer gas

Other gases and gas mixtures on request.

Particles, humidity and condensation

- dust or fibre particles in the gas do not affect the measurement, as long as these are not abrasive or accumulate on the sensor
- measurement uncertainty remains unaffected by a relative gas humidity of less than 100 % and a slight accumulation of condensate on the sensor



Model designation / order code (example)

VA Di 25	G	E	40 m/s	p10	ZG1	Ex-d
(1)	(2)	(3)	(4)	(5)	(6)	(7)

Basic types

Type	Article No.
VA Di 25 GE 25 m/s / p10 ZG1 Ex-d	B015/055
VA Di 25 GT 25 m/s / p10 ZG1 Ex-d	B015/060
VA Di 25 GH 25 m/s / p10 ZG1 Ex-d	B015/065
VA Di 25 GL 25 m/s / p10 ZG1 Ex-d	B015/070
VA Di 40 GE 30 m/s / p10 ZG1 Ex-d	B015/056
VA Di 40 GT 30 m/s / p10 ZG1 Ex-d	B015/061
VA Di 40 GH 30 m/s / p10 ZG1 Ex-d	B015/066
VA Di 40 GL 30 m/s / p10 ZG1 Ex-d	B015/071
VA Di 50 GE 30 m/s / p10 ZG1 Ex-d	B015/057
VA Di 50 GT 30 m/s / p10 ZG1 Ex-d	B015/062
VA Di 50 GH 30 m/s / p10 ZG1 Ex-d	B015/067
VA Di 50 GL 30 m/s / p10 ZG1 Ex-d	B015/072
VA Di 80 GE 40 m/s / p10 ZG1 Ex-d	B015/058
VA Di 80 GT 40 m/s / p10 ZG1 Ex-d	B015/063
VA Di 80 GH 40 m/s / p10 ZG1 Ex-d	B015/068
VA Di 80 GL 40 m/s / p10 ZG1 Ex-d	B015/073
VA Di 100 GE 40 m/s / p10 ZG1 Ex-d	B015/059
VA Di 100 GT 40 m/s / p10 ZG1 Ex-d	B015/064
VA Di 100 GH 40 m/s / p10 ZG1 Ex-d	B015/069
VA Di 100 GL 40 m/s / p10 ZG1 Ex-d	B015/074

(1) Dimensions

tube inside ∅ Di [mm]	flange outside ∅ D [mm]	flange thickness b [mm]	hole circle ∅ k [mm]	hole ∅ d [mm]	number of holes	sensor length [mm]	sensor height H [mm]
25	115	16	85	14	4	200	276
40	150	16	110	18	4	200	290
50	165	18	125	18	4	200	290
80	200	20	160	18	8	200	302
100	220	20	180	18	8	200	318

Flange dimensions according to EN 1092-1 PN16 Form B1 (other dimensions on request)

(2) Medium

Gases



(3) Materials in contact with the medium

Design	Material
... GE ...	stainless steel 1.4571, ceramics
... GT ...	titanium 3.7161, ceramics
... GH ...	Hastelloy 2.4610 (HC4), ceramics
... GL ...	tantalum, ceramics

(4) Measuring range

Di [mm]	flow rate V/t [m³/h]	average flow velocity v _m [m/s]	interrelationship v _m - V/t
25	0.7 ... 44	0.4 ... 25	1 m/s = 1.77 m³/h
40	1.8 ... 135	0.4 ... 30	1 m/s = 4.52 m³/h
50	2.8 ... 212	0.4 ... 30	1 m/s = 7.07 m³/h
80	7.2 ... 724	0.4 ... 40	1 m/s = 18.1 m³/h
100	11.0 ... 1131	0.4 ... 40	1 m/s = 28.3 m³/h

Measurement uncertainty	< 1 % of measured value + 0.3 % FS (at +20 °C / 1000 hPa)
Repeatability	± 0.2 % of measured value + 0.025 % FS
Input/output sections	in order to achieve as great a measurement accuracy as possible, an input/output section of 20/10 x Di is recommended. The input section can be reduced considerably by using a flow rectifier (see Accessories). Further information on this subject can be found in the Operating Instructions U283_VADi.

(5) Maximum working pressure

up to 10 bar / 1 MPa overpressure

(6) Design

as in Drawing 1 (Page 1)

(7) ATEX protection

for gas	: Ⓜ II 1/2 G Ex ia/d e [ia] IIC T6 Ga/Gb
for dust	: Ⓜ II 1/2 D Ex ia/tb IIIC TX Da/Db
sensor	: Category 1 (Zone 0 or 20)
transducer housing	: Category 2 (Zone 1 or 21)

Ex-d transducer housing

Dimensions	outside diameter/length/height: approx. 110/205/182 mm
Material	aluminium cast alloy max. 0.5 % Mg, coated
Protection	IP68, IEC 529 and EN 60 529
Connection	glands for shielded cables with outside diameter 5 ... 9 mm; contacting of overall screen on the ground terminal in the housing; via screw terminals Ex-e for wires with cross-section 0.14 – 1.5 mm²
Alignment	rotatable by approx. 350 ° and lockable
Setup	dual chamber system consisting of: 1) electronics in Ex-d protection (flameproof enclosure) 2) connections in Ex-e protection (increased safety) with terminal block and cable glands



Electromagnetic Compatibility (EMC)

according to EN 61 000-6-2 / IEC77

Installation position

any	to ensure that sensors remain operative in horizontal pipelines, even with slight accumulation of condensate, VA Di 25 sensors should be installed with the connection housing facing upwards, and VA Di 40, 50, 80 and 100 sensors with the connection housing facing sideways. In the case of vertical pipelines positioning of all VA Di sensors - even with slight accumulation of condensate - can be chosen freely.
-----	--

Options (A) & (B)

Sealing material	Calibration pressure
(A)	(B)

Option (A) Sealing material

Material	Permissible temperature of the medium	Permissible ambient temperature	Article No.
VITON [®] (standard)	-20 ... +180 °C	-20 ... +50 °C	B015/900
silicone	-40 ... +180 °C	-25 ... +50 °C	B015/901
KALREZ [®] (Compound 4079)	0 ... +180 °C	0 ... +50 °C	B015/902
EPDM	-20 ... +160 °C	-20 ... +50 °C	B015/903

Option (B) Calibration pressure

Pressure	Comments	Article No.
atmospheric	at working pressures greater than 3 bar rel., calibration should be carried out at an average working pressure to reduce measurement uncertainty	B015/910
___ bar rel.	calibration pressure selectable in range 1 ... 10 bar rel.; at working pressures higher than 3 bar rel., calibration at an average working pressure is recommended to ensure the best possible measurement uncertainty	B015/911



Transducer UVA integrated in the connection housing

Analog output flow	4 ... 20 mA resistance max. 500 Ohm
Output limit value or quantity pulse	potential-free relay contact (normally-open) max. 300 mA / 27 VDC
Communication port	HART® via modem adapter for PC connection and UCOM software (see Accessories)
	output signals electrically isolated from power supply
Self-monitoring	parameter settings, sensor interface; in the case of error: analog output < 3.6 mA
Power supply	24 V DC (20 ... 27 V DC)
Power consumption	less than 5 W
Setting parameters (selection depending on parameter set)	analog output, time constant, profile factor, limit value or quantity pulse (rating adjustable), switchover actual/standard flow with parameters 'working pressure' and 'working temperature'

Accessories (optional)

	Description	Article No.
LCD display	1 st row: 'instantaneous value': flow rate or flow velocity 2 nd row: 'counter' or 'error code' 2 x 16-digit, character height 5.5 mm, working temperature range -20 ... +50 °C display rotatable in 90 °-stages on removing the Ex-d housing window cover	A010/520
Calibration certificate v/VA		KLB
HART® modem adapter	for changing setting parameters, for PC-USB connection	A010/101
PC software UCOM	for configuring the UVA via RS232	A010/052



Ex-d transducer housing with optional LCD display



Accessories (cont'd)

Process flange TP

for one pressure sensor (P) and one temperature sensor (T)

Identification	Article No.	Inside Di [mm]
TP Di/DN 25 PN16	B015/100	25
TP Di/DN 40 PN16	B015/101	40
TP Di/DN 50 PN16	B015/102	50
TP Di/DN 80 PN16	B015/103	80
TP Di/DN100 PN16	B015/104	100
Material	stainless steel 1.4571	
Connecting thread	2 x G 1/4"	
Installation point	downstream, behind the VA Di sensor	

Flow rectifier

for reducing the input section - incl. flow rectifier - to 11 x Di

Identification	Article No.	Inside Di [mm]
GL Di/DN25 PN16	B015/150	25
GL Di/DN40 PN16	B015/151	40
GL Di/DN50 PN16	B015/152	50
GL Di/DN80 PN16	B015/153	80
GL Di/DN100 PN16	B015/154	100
Material	stainless steel 1.4571	
Installation point	5 ... 8 x Di in front of the VA Di Sensor (see Operating Instructions U283)	

® Registered trademark:
Dupont: VITON, KALREZ
HART: HART Communication
Foundation

Höntzsch GmbH

Gottlieb-Daimler-Straße 37
D-71334 Waiblingen (Hegnach)
Telefon +49 7151 / 17 16-0
Telefax +49 7151 / 5 84 02
E-Mail info@hoentzsch.com

จัดจำหน่ายโดย

บริษัท โอเมก้า เมชเชอริง อินสตรูमेंท์ จำกัด
50/23 หมู่ 3 ต.มหาสวัสดิ์ อ.บางกรวย จ.นนทบุรี 11130
Tel : 02 105 4676
Fax : 02 903 0080 ext. 6867
Email : info@omi.co.th